

# DRI

VARIZON® Displacement unit with adjustable spread pattern



## QUICK FACTS

- Varizon® air distribution system
  - Adjustable spread pattern and affected area
- Suitable for all types of rooms
- Cleanable
- Air volume measuring point
- Very simple to install in suspended ceilings or in walls
- Concealed fastening
- Standard colour White RAL 9003
  - 5 alternative standard colours
  - Other colours upon request

DRI Size	SOUND PRESSURE ROOM (Lp150A) *)					
	25 dB(A)		30 dB(A)		35 dB(A)	
	l/s	m <sup>3</sup> /h	l/s	m <sup>3</sup> /h	l/s	m <sup>3</sup> /h
200	220	792	265	954	315	1134
250	340	1224	400	1440	480	1728
315	515	1854	610	2196	720	2592
400	790	2844	930	3348	1100	3960
200-600	610	2196	725	2610	860	3096
250-800	840	3024	980	3528	1150	4140

Sound level is valid at 150 m<sup>2</sup> equivalent sound absorption area at distance of 2 m from terminal. All values are valid on straight duct section without disturbance.

\*)  $L_{p10A}$  = Sound pressure incl. A-filter with 16 dB room attenuation and 150 m<sup>2</sup> room absorption area.

# Technical description

## Design

- DRI is a complete flat rectangular low velocity diffuser
- Recommended placement is on the floor or wall.
- Can be placed in ceilings.
- The body consists of a rear section with side, top and bottom plates and Varizon air distribution system with an air diffusion plate which is equipped with adjustable deflectors of polypropylene-PP.
- Circular connection to inlet socket for sizes 200 to 400.
- Rectangular connection for sizes 200-600 and 250-800.
- Cleaning hatch is in the air distribution plate, see figure 2.
- The front consists of one or two perforated front plates, see figure 1.
- 4 white enamelled angle strips are supplied with the air diffuser and are used for recessed installation in the wall.
- NOTE! Installation accessories are not supplied with the product.

## Materials and surface treatment

The displacement unit is manufactured in galvanized sheet steel and aluminum profiles. It is coated with paint.

- Standard colour:
  - White semi-gloss, lustre 40, RAL 9003/NCS S 0500-N
- Alternative standard colours:
  - Silver gloss, lustre 80, RAL 9006
  - Grey aluminium gloss, lustre 80, RAL 9007
  - White semi-gloss, lustre 40, RAL 9010
  - Black semi-gloss, lustre 35, RAL 9005
  - Grey semi-gloss, lustre 30, RAL 7037
- Non-painted finish and other colours available on request.

## Customising

In addition to the standard sizes, these displacement units are available in special dimensions, with reinforced front plates etc. Please, contact your nearest sales representative for further information.

## Planning

- The rotating distribution plates behind the front panel make it possible to change the distribution in the near zone without affecting the air flow, pressure drop or sound level.
- NOTE! Sizing diagrams specify data at 150 m<sup>2</sup> equivalent absorption area.
- Sound data increases by about 10 dB(A) if this concerns a standardized room for 10 m<sup>2</sup> equivalent absorption area.
- Extra consideration must be given to how to connect duct connected diffusers without generating extra additional sound. See figure 3.

## Installation

- Installation example is shown in Figure 1.
- The air diffuser is screwed to the wall. Installation accessories are not included in the delivery.
- Possible ceiling installation requires the use of drop rods or mounting strips/angle bar to secure the diffuser to a solid ceiling structure. Installation accessories are not included
- If the air diffuser is flush-mounted, use the supplied enamelled angle strips as a frame around the air diffuser to cover the opening. Installation accessories are not included in the delivery.
- E64 For ceiling installation, the front plate for sizes 200 and 250 must be secured using the two supplied screws.

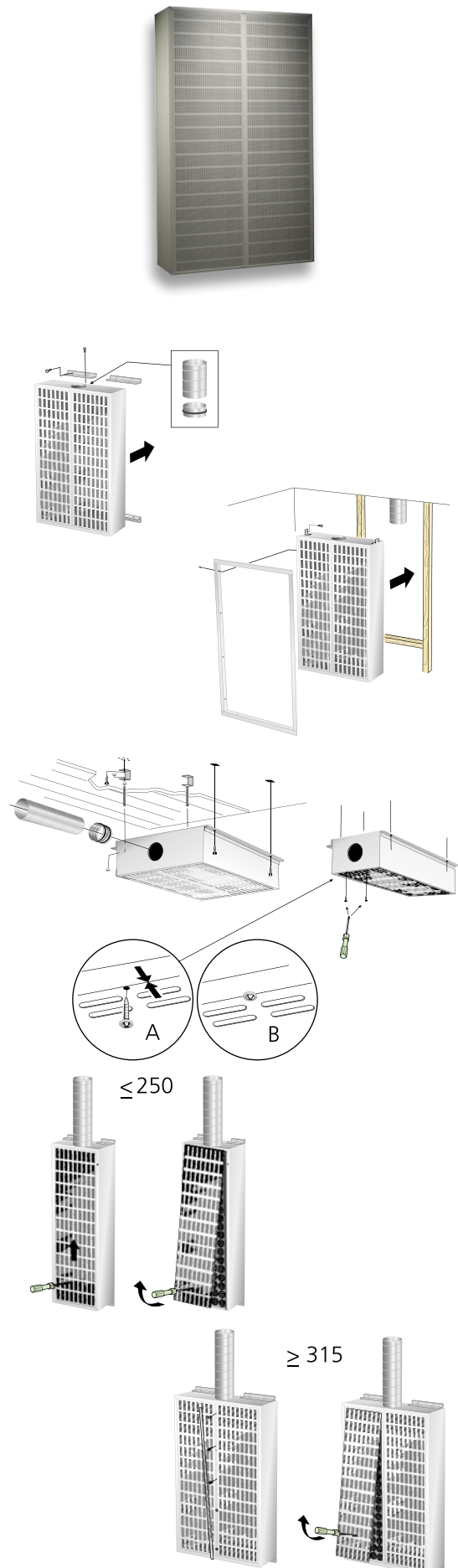

Figure 1. Installation.

### Commissioning

- The K-factor can be found on the diffuser's product labelling, see Figure 2.
- DRI sizes 200 and 250 have measurement tapings located on the front edge of the diffuser (remove the plastic plug).
- DRI size 315 and larger have measurement tapings placed behind the decor strip.
- Adjust the air flow with a measuring and commissioning damper, not included with the product. This damper should be located upstream of the air diffuser's inlet at a distance equal to at least 3 duct diameters.

### Maintenance

- Clean, if necessary, using lukewarm water with dishwashing detergent added.
- Alternatively a vacuum cleaner with a suitable brush nozzle can also be used.
- The duct system can be accessed by removing the front panel and the air distribution panel's inspection cover. See Figure 2.

### Environment

The declaration of construction materials is available from [www.swegon.com](http://www.swegon.com).

## Sizing

- Sound level dB(A) applies to rooms of 150 m<sup>2</sup> equivalent absorption area, which gives 16 dB room attenuation, and measured 2 m from the displacement unit and with a straight section without disturbance on straight duct section.
- Recommended maximum under temperature is 6 K.
- To calculate the width of the spread pattern, air velocities in the zone of occupation or sound levels in rooms with other dimensions, please refer to our calculation program ProAir web, available for download from [www.swegon.com](http://www.swegon.com).

## Sound data – DRI

### Sound power level L<sub>w</sub>(dB) (150 m<sup>2</sup> Sabine)

Table K<sub>OK</sub>

Size DRI	Mid-frequency (Octave band) Hz							
	63	125	250	500	1000	2000	4000	8000
200	14	18	17	14	11	5	-2	-10
250	15	19	18	14	10	4	-2	-6
315	18	18	16	14	12	6	0	-8
400	17	19	18	15	10	4	-3	-7
200-600	17	18	18	15	10	4	-6	-11
250-800	17	19	19	15	9	1	-11	-11
Tol. ±	2	2	2	2	2	2	2	2

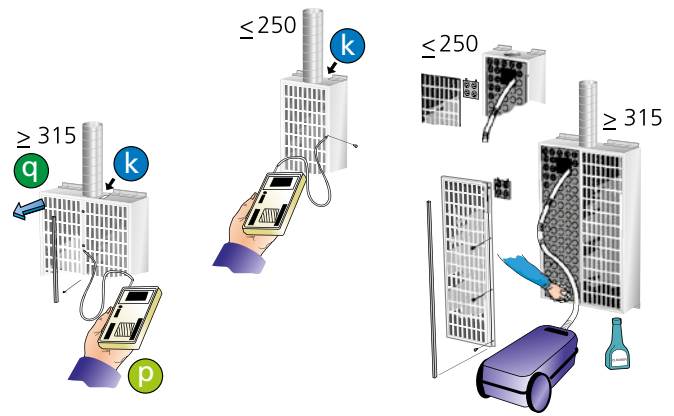

$$q = k \cdot \sqrt{p}$$

$$p = \left(\frac{q}{k}\right)^2$$

Figure 2. Commissioning. Maintenance.

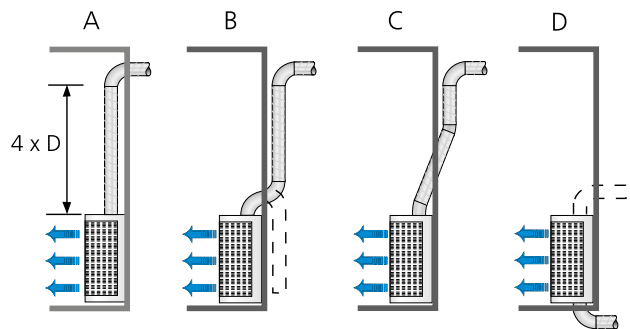

Figure 3. E.g. of how different duct connections affect the sound level of the terminal. See table.

### Sound attenuation ΔL (dB) (150 m<sup>2</sup> Sabine)

Table ΔL

Size DRI	Mid-frequency (Octave band) Hz							
	63	125	250	500	1000	2000	4000	8000
200	17	12	6	2	2	3	5	4
250	15	10	5	2	2	3	4	5
315	14	9	4	1	0	1	2	2
400	13	6	4	1	1	1	1	1
200-600	10	4	1	0	0	0	0	0
250-800	9	3	1	0	0	0	0	0
Tol. ±	2	2	2	2	2	2	2	2

### Table – Duct connections

Effects on sound levels (dB) for different duct connections and different air velocities in straight duct sections.

Velocity (FPM)	Duct connections (dB)			
	A	B	C	D
785 - 985	+ 2	+ 6	+ 3	+ 3
1180 - 1580	+ 4	+ 10	+ 6	+ 6

## Engineering graphs – DRI

### Air flow – Pressure drop – Sound level – Affected area

- The graphs show data for sound levels in a room with an absorption area equivalent of 150 m<sup>2</sup> and measured 2 m from the displacement unit and at a straight section without disturbance on straight duct section. See figure 3 how different duct connections will affect the sound level.
- At the equivalent room absorption area of 10 m<sup>2</sup> and 2 m from the nozzle the noise level increases by approx. 10 dB(A).
- The affected area refers to a displacement unit installed on a wall, 100 mm from the floor. The affected area distance is related to the isovel limit of 0.2 m/s at  $\Delta t$  3 K.
- The graphs are not to be used for commissioning.
- $\nabla$  = min air flow to obtain sufficient commissioning pressure.
- The dB(C) values normally lie 6-9 dB higher than dB(A) values.
- For  $\Delta t = 6$  K the measurements  $a_{0,20}$  and  $b_{0,20}$  are increased by approx. 20%.

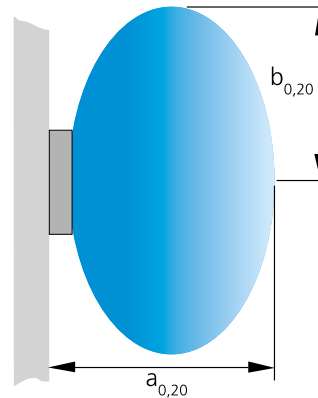
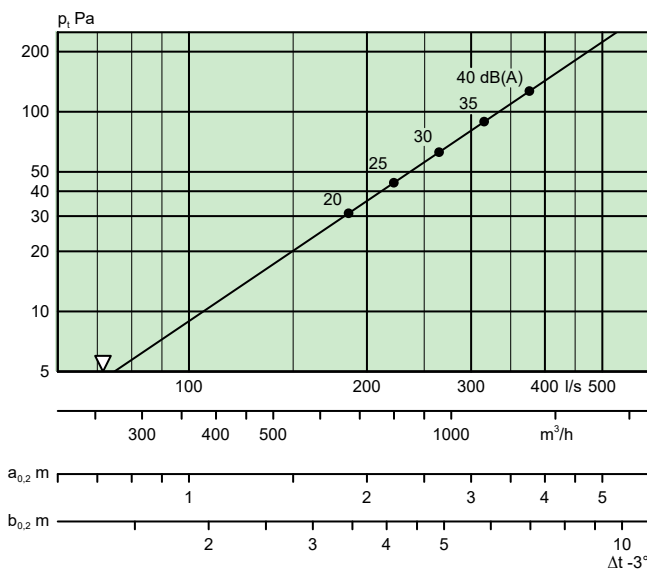
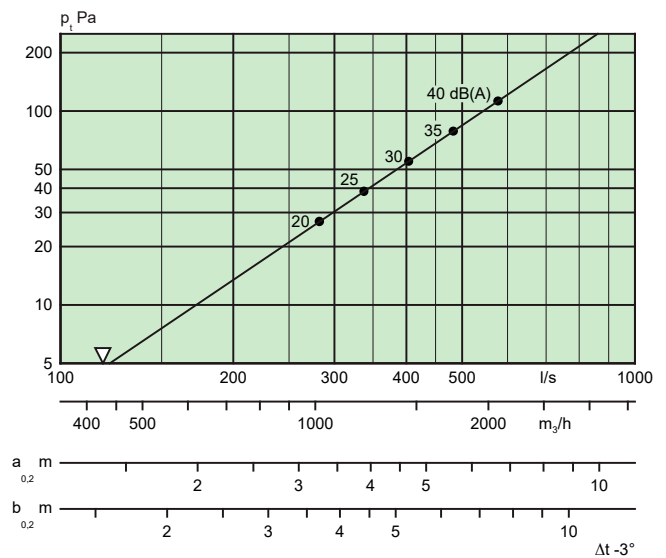

Figure 4. Affected area.

### DRI 200 (150 m<sup>2</sup> Sabine)



### DRI 250 (150 m<sup>2</sup> Sabine)



### DRI 315 (150 m<sup>2</sup> Sabine)

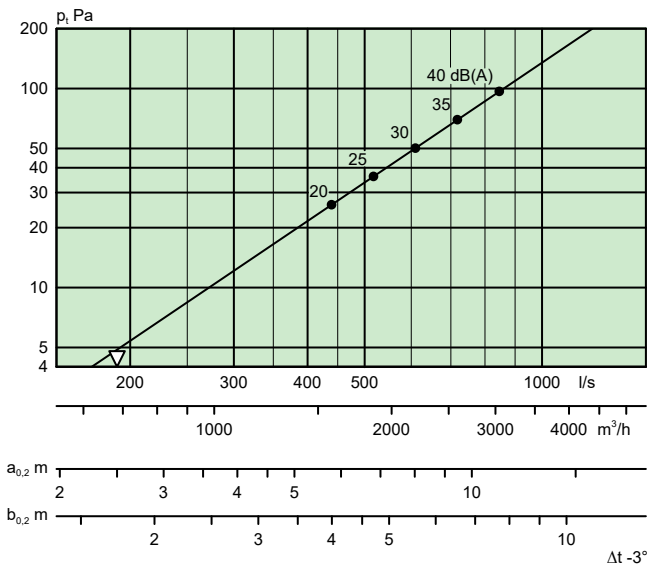

### DRI 400 (150 m<sup>2</sup> Sabine)

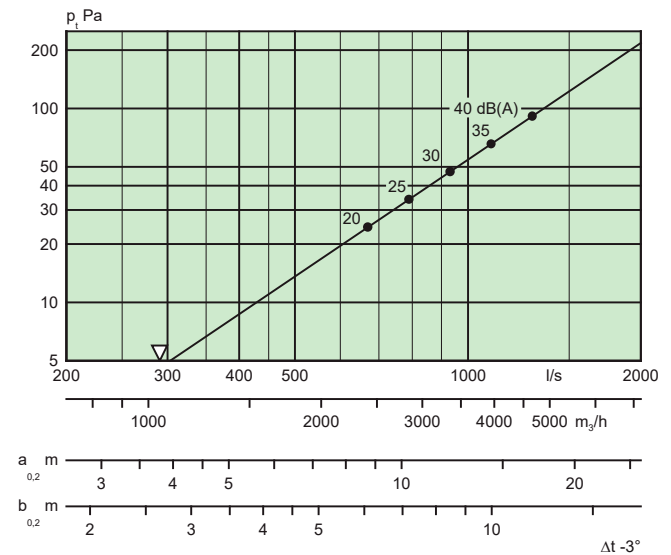

**DRI 200-600 (150 m<sup>2</sup> Sabine)**

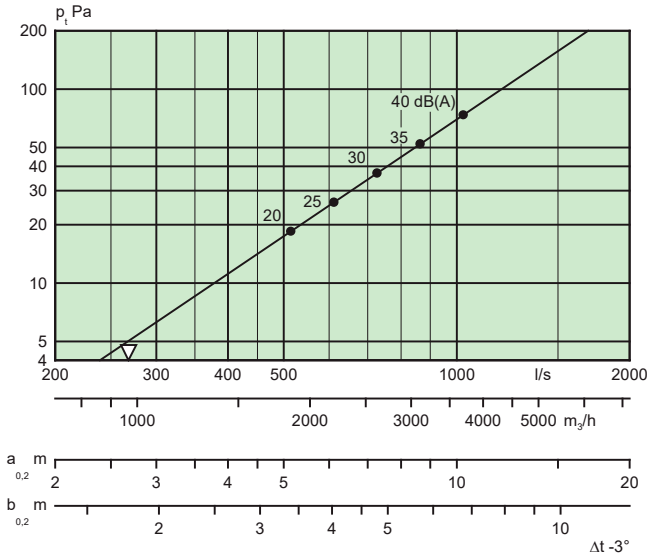

**DRI 250-800 (150 m<sup>2</sup> Sabine)**

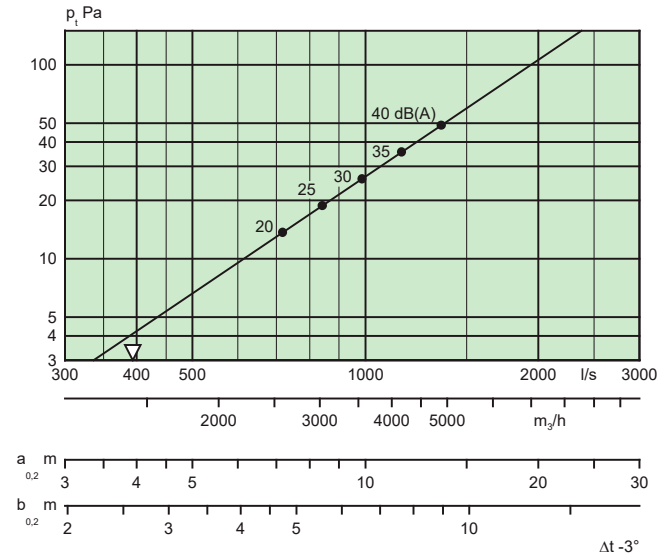

## Dimensions and weights

Size DRI	Dimensions (mm)							Weight (kg)
	A	B	C	ØD	E	F x G	H	
200	590	1190	300	200	115	-	0	23
250	590	1990	350	250	140	-	0	41
315	1190	1990	415	315	173	-	0	78
400	1190	1990	500	400	215	-	0	81
200-600	1190	1990	300	-	-	200 x 600	55	73
250-800	1190	1990	350	-	-	250 x 800	75	75

The DRI models with circular duct connections have an internal socket connection.

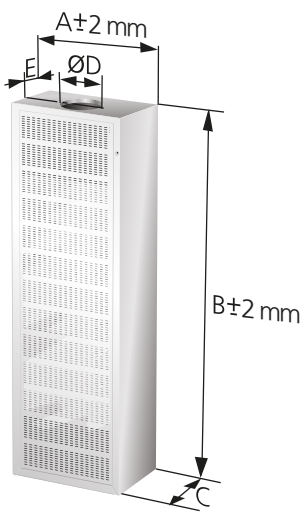

Figure 5a. DRI 200, 250.

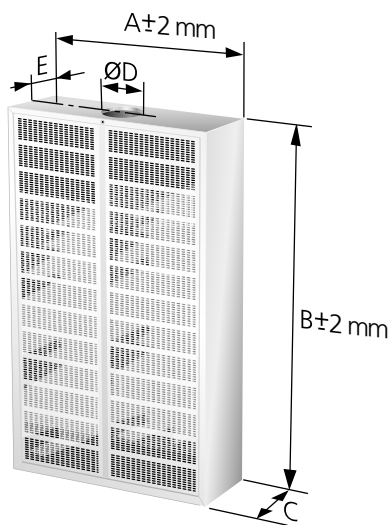

Figure 5b. DRI 315, 400.

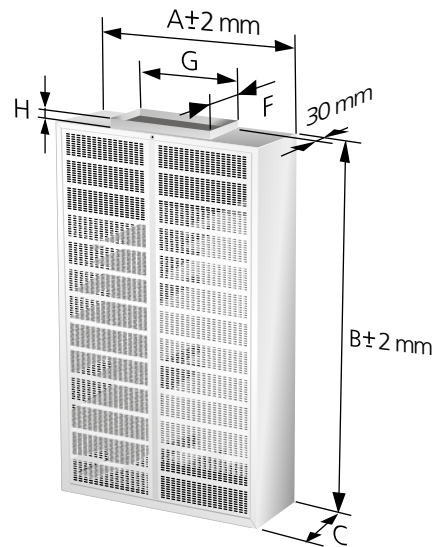

Figure 6. DRI 200-600, 250-800.

## Order key

### Product designation

Rectangular displacement unit with circular connection     DRI     f     -aaa

Version:

Size: 200, 250, 315, 400

Rectangular displacement unit with rectangular connection     DRI     f     -aaa - bbb

Version:

Size: 200-600, 250-800

## Specification example

Swegon VARIZON® rectangular displacement unit DRI, with the following functions:

- Adjustable spread pattern and affected area
- Interchangeable front sections
- Non-fouling
- Air volume measuring point
- Cleanable
- Cover strips for flush mounting
- Powder painted in white, RAL 9003/NCS S 0500-N

Size:                     DRIf aaa - bbb     xx items