

REACT V BBAC

Variable flow damper – Belimo BACnet



QUICK FACTS

- Variable or constant flow regulation
- Can be mounted directly at bends and duct transitions/reductions (circular)
- Setting/reading of parameters via the hand-held terminal ZTH EU, PC-Tool or BACnet
- Analogue control and BACnet control
- Can be easily anti-condensation insulated in the duct system
- Variants:
 - Circular connections: Ø100-630 mm
 - Rectangular connections: 200x200-1400x700 mm

REACT V BBAC Size	FLOW RANGE					
		Min.		Max.*		
	l/s	m ³ /h	cfm	l/s	m ³ /h	cfm
100	5	18	11	58	209	123
125	9	32	19	97	349	206
160	16	58	34	170	612	360
200	25	90	53	272	979	576
250	40	144	85	438	1577	928
315	63	227	133	710	2556	1504
400	102	367	216	1155	4158	2447
500	164	590	347	1850	6660	3920
630	300	1080	636	2920	10512	6187

*Nominal flow (V_{nom}), based on 120 Pa in pressure reading.

Content

Technical description	3
General.....	3
Design	3
Circular design	3
Rectangular design	3
Functions.....	3
Materials and surface treatment.....	3
Project design / Typical room.....	3
Maintenance.....	3
Environment	3
Accessories	3
Technical data	4
Electrical data	4
Connection.....	4
Sizing	5
Circular design	5
Acoustic data.....	5
Sizing diagram	5
Rectangular design	7
Acoustic data.....	7
Sizing diagram	7
Installation, torque, dimensions and weights...8	
Circular design	8
Dimensions.....	8
Installation.....	9
Rectangular design	10
Dimensions.....	10
Installation	11
Specification.....	12
Specification text.....	13

Technical description

General

- Intended for flow regulation of comfort ventilation.
- Moist, cold and aggressive environments must be avoided.
- Can be installed in both supply and extract air systems.
- Pressure independent but recommended working range between minimum pressure drop of 10 Pa to 300 Pa over the damper.
- The minimum air flow must be considered during design.
- For good regulation, a minimum difference between V_{min} and V_{max} of 20% of the product's V_{nom} is recommended.

Design

- Integrated air flow sensor.
- Analogue controls and BACnet control.

Circular design

- Connection: Ø100-630 mm.
- Always supplied with dust protection.
- Motor shelf with 25 mm spacer to facilitate condensation insulation of the duct system.
- A factory-insulated model available on request.

Rectangular design

- Connection 200x200-1400x700 mm.
- Other sizes are also available on request.

Functions

- Variable or constant flow regulation.
- Measurement of air flow.
- Setting and reading of parameters on the controller via the external hand-held terminal ZTH EU or PC-Tool.

Materials and surface treatment

- All sheet-metal parts are galvanized sheet steel (Z275).
- Measuring rods are aluminium.

Project design / Typical room

See separate documentation "REACT Belimo Description of functions & wiring diagram", available for download via www.swegon.com.

Maintenance

The product does not require any maintenance/service, except for any cleaning when necessary. See the separate Instructions for Use, available on www.swegon.com.

Environment

The Building Materials Declaration is available on www.swegon.com.

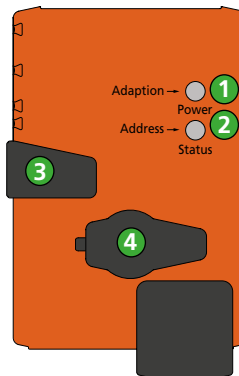
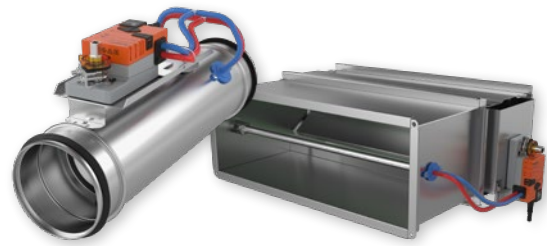

Figure 1. REACT V BBAC controller.
 1. Pushbutton and LED lighting green
 2. Pushbutton and LED lighting yellow
 3. Release button
 4. Service port

Accessories

REACT V COVER CIRCULAR	Cover panel for circular design in case of visible installation
FSR	Clamp for easy dismantling of a circular design for cleaning and inspection
ZTH EU	Hand-held terminal for setting of parameters on the actuator
DETECT Occupancy V110	Occupancy detector for wall and corner installation
DETECT Occupancy T360	Occupancy detector for ceiling installation
LUNA RC	Room controller for temperature regulation, with display
LUNA RC CO ₂	Room controller for temperature and CO ₂ regulation, with display
LUNA RE	Room controller for temperature regulation
DETECT IAQ	CO ₂ - and temperature controller
DETECT IAQ OCS	CO ₂ - and temperature controller that also detects occupancy
DETECT IAQ D	CO ₂ - and temperature controller for duct installation



Technical data

IP class:	IP54
Corrosivity class:	C3
Pressure class:	A
Leakage classes according to SS-EN 1751	
- Leakage class, casing:	C
- Leakage class circular damper, closed:	4
- Leakage class rectangular damper, closed:	3
Running times open/close (90°):	
5 Nm:	100 s
10 / 20 Nm:	150 s
Ambient temperature	
Operation:	0 – +50°C
Storage:	-20°C – +80°C
RH:	5 – 95% (non-condensing)
CE marking:	2006/42/EC (MD) 2014/30/EU (EMC) 2011/65/EU (RoHS2)

Electrical data

Power supply:	24 V AC/DC ±15% 50 - 60 Hz	
Fixed connection cable, 1000 mm with cable size.	6 x 0,75 mm ² <i>See figure 2 below.</i>	
Power consumption, for transformer rating:		
REACT V BBAC 5 Nm	2.0 W	4.0 VA
REACT V BBAC 10 Nm	3.0 W	5.0 VA
REACT V BBAC 20 Nm	3.0 W	5.5 VA

See torque in tables on pages 8 and 10.

Connection

1-2 – Supply voltage	24 V AC/DC
3 – Control signal (Y)	0..10/(2..10) V DC
5 – Actual value signal (U)	0..10/(2..10) V DC
6 – BACnet (C ₁ = D- = A)	
7 – BACnet (C ₂ = D+ = B)	

Supply voltage and communication are not galvanically isolated.

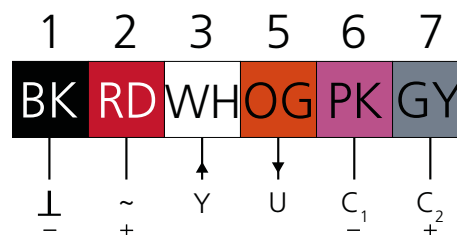

Figure 2. Connection.

Sizing

Circular design

- Important! Increased air flow gives increased duct velocity and increased sound level.

Acoustic data

Sound power level

- The diagrams show the A-weighted sound power (L_{WA} -dB), as a function of the air flow and pressure drop across the damper.
- Correct L_{WA} with correction factor K_{ok} from the tables below to obtain the sound power levels for each octave band ($L_W = L_{WA} + K_{ok}$).

Correction factors for conversion to sound power in octave bands:

L_{WA} = Sound level with A-filter but without room attenuation in the sizing diagram for duct products.

K_{ok} = Correction factor in octave bands.

K_{trans} = Correction factor in octave bands for transmitted sound.

Sound power in octave bands

$$L_W = L_{WA} + K_{ok} \text{ [dB]}$$

Correction factor K_{ok}

Size	Mid-frequency (octave band) Hz							
	63	125	250	500	1000	2000	4000	8000
100	7	7	5	-1	-5	-10	-17	-22
125	7	9	6	-2	-4	-10	-19	-25
160	5	10	6	-3	-5	-11	-18	-24
200	5	10	5	-2	-5	-11	-19	-27
250	8	5	2	-3	-6	-10	-18	-24
315	4	6	3	-3	-6	-10	-18	-25
400	6	3	1	-3	-5	-10	-17	-26
500	3	0	-1	-3	-5	-10	-17	-28
630	3	-1	-2	-3	-5	-9	-17	-27
Tol ±	6	3	2	2	2	2	2	2

Transmitted sound through uninsulated casing

$$L_W = L_{WA} + K_{trans} \text{ [dB]}$$

Correction factor K_{trans}

Size	Mid-frequency (octave band) Hz							
	63	125	250	500	1000	2000	4000	8000
100	-2	-9	-7	-10	-9	-10	-15	-22
125	-4	-9	-8	-13	-9	-12	-19	-27
160	-7	-9	-10	-15	-12	-15	-20	-28
200	-9	-11	-13	-16	-14	-16	-23	-32
250	-8	-18	-17	-19	-17	-17	-23	-31
315	-14	-19	-18	-21	-18	-19	-25	-34
400	-13	-23	-22	-22	-19	-21	-26	-37
500	-18	-28	-27	-24	-21	-22	-28	-40
630	-18	-27	-27	-24	-21	-21	-29	-38
Tol±	6	3	2	2	2	2	2	2

Sizing diagram

Air flow – Pressure drop – Sound level

- Specified sound levels L_{WA} : 30, 35, 40, 45 and 50 dB(A).
- The data is for the sound created in ducts.
- 100% corresponds to the damper being fully open.
- ▽ = Min. flow

REACT V BBAC 100

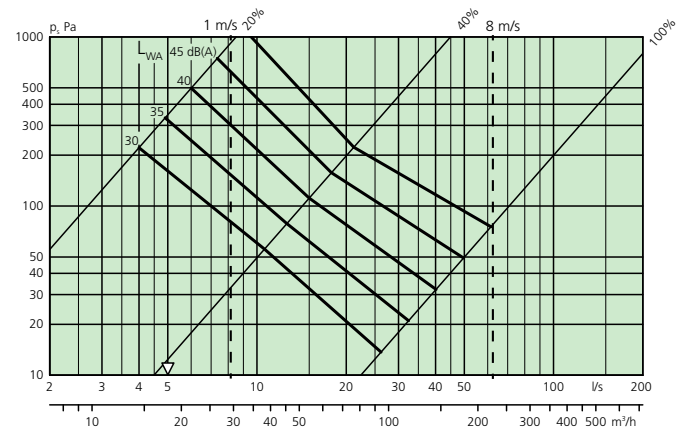

REACT V BBAC 125

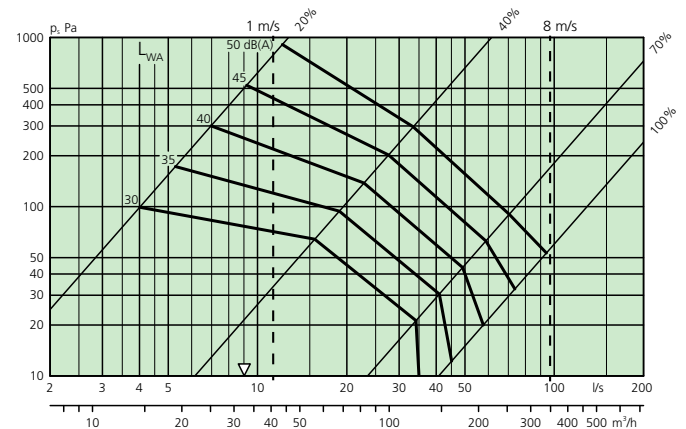

REACT V BBAC 160

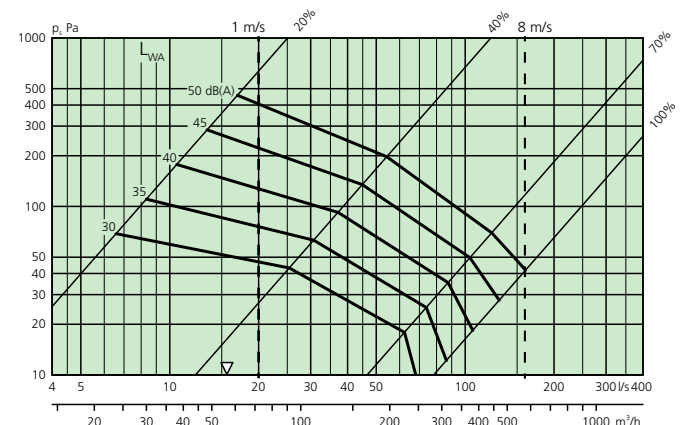

REACT V BBAC 200

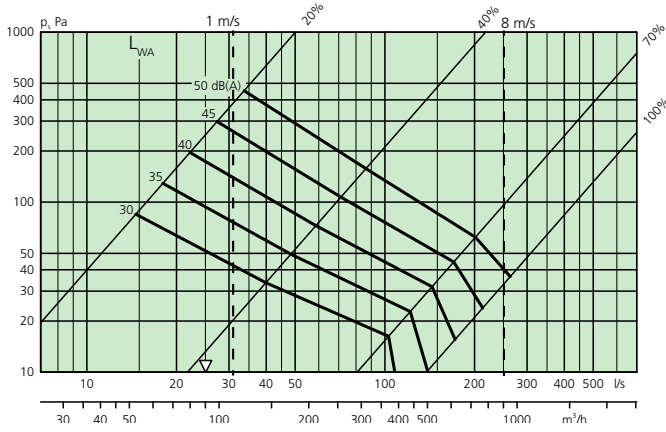

REACT V BBAC 400

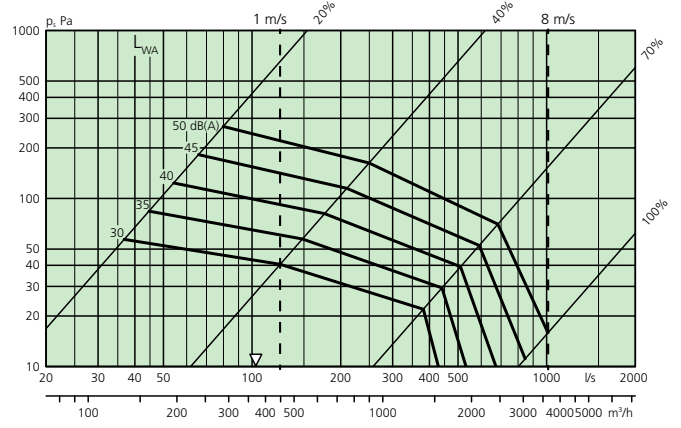

REACT V BBAC 250

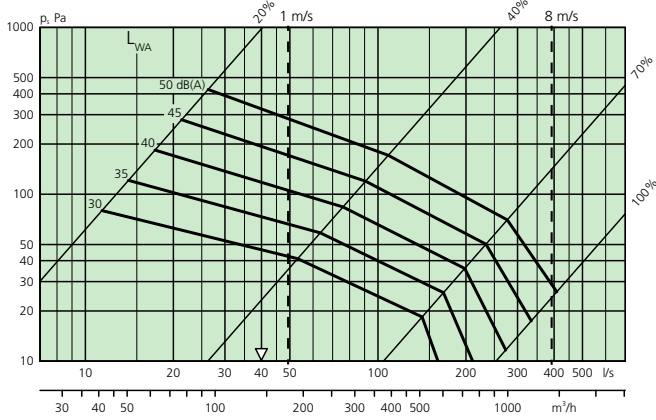

REACT V BBAC 500

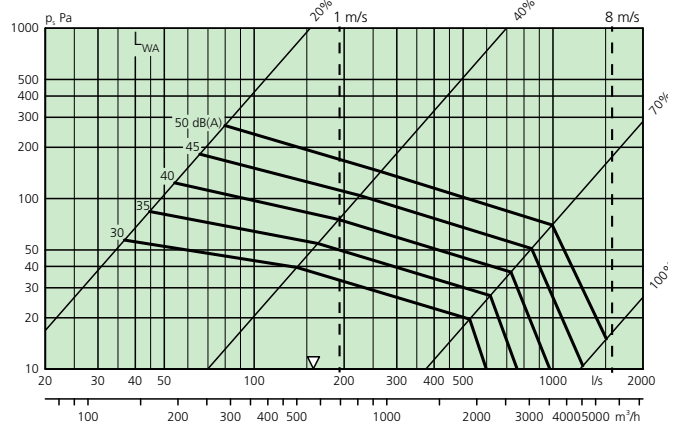

REACT V BBAC 315

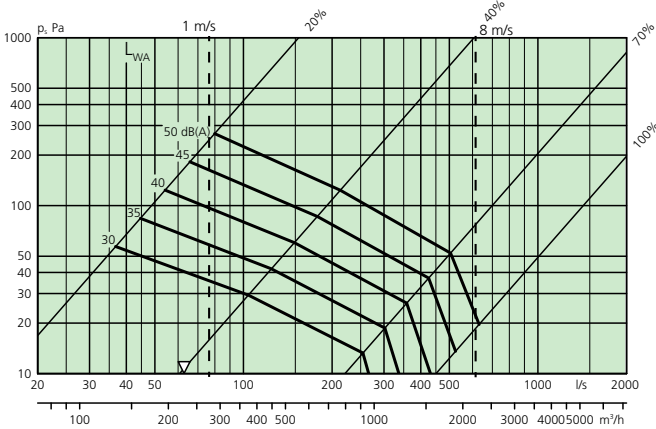

REACT V BBAC 630

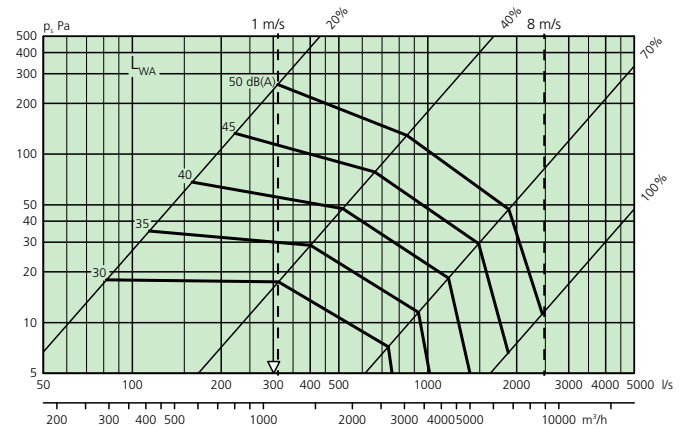

Rectangular design

- Important! Increased air flow gives increased duct velocity and increased sound level.

Acoustic data

Sound power level

- The diagrams show the A-weighted sound power (L_{WA} -dB), as a function of the air flow and pressure drop across the damper.
- Correct L_{WA} with correction factor K_{ok} from the tables below to obtain the sound power levels for each octave band ($L_W=L_{WA}+K_k+K_{ok}$).

Sound power in octave bands

$$L_W = L_{WA} + K_k + K_{ok}$$

Correction factor K_{ok}

Size	Mid-frequency (octave band) Hz							
	63	125	250	500	1000	2000	4000	8000
All	7	3	1	0	-5	-14	-23	-22
Tol. ±	4	4	3	2	2	2	2	2

Correction factor K_k for the damper's face area

Correction factor – face area								
Area m ²	0.1	0.15	0.25	0.4	0.6	1.0	1.6	2.5
K_k	-3	-2	0	2	4	6	8	10

Sizing diagram

Velocity - Pressure drop - Sound level

- The data is for the sound created in ducts.
- Specified sound levels L_{WA} : 40, 50, 60 and 70 dB.
- Calculate the face velocity across the damper and read the sound data and pressure drop at an appropriate damper position.
- 100% corresponds to the damper being fully open.

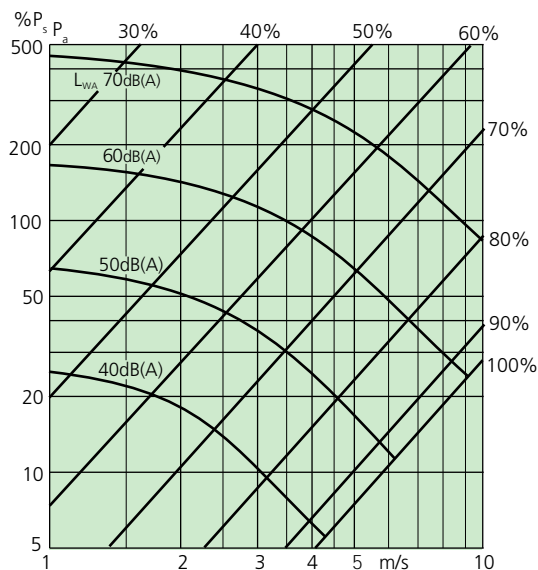

Installation, torque, dimensions and weights

Circular design

Dimensions

Size Ød (mm)	A (mm)	B (mm)	C (mm)	E (mm)	Torque (Nm)	Weight (kg)	Flow range						Tolerance Q* ±5% with at least ±x		
							Min.			Max = Vnom ^{*)}					
							l/s	m ³ /h	cfm	l/s	m ³ /h	cfm	l/s	m ³ /h	cfm
100	475	485	190	50	5	1.6	5	18	11	58	209	123	2	7	4
125	475	485	215	50	5	1.8	9	32	19	97	349	206	2	7	4
160	475	485	255	50	5	2.1	16	58	34	170	612	360	2	7	4
200	475	485	300	50	5	2.7	25	90	53	272	979	576	3	11	6
250	525	535	350	50	5	3.4	40	144	85	438	1577	928	5	18	11
315	560	570	415	50	10	4.8	63	227	133	710	2556	1504	8	29	17
400	695	705	505	60	10	6.8	102	367	216	1155	4158	2447	13	47	28
500	820	840	605	60	10	9.4	164	590	347	1850	6660	3920	20	72	42
630	915	935	735	60	20	14.4	300	1080	636	2920	10512	6187	32	115	68

^{*)}Vnom at 120 Pa in pressure reading.

*Installed according to the instructions.

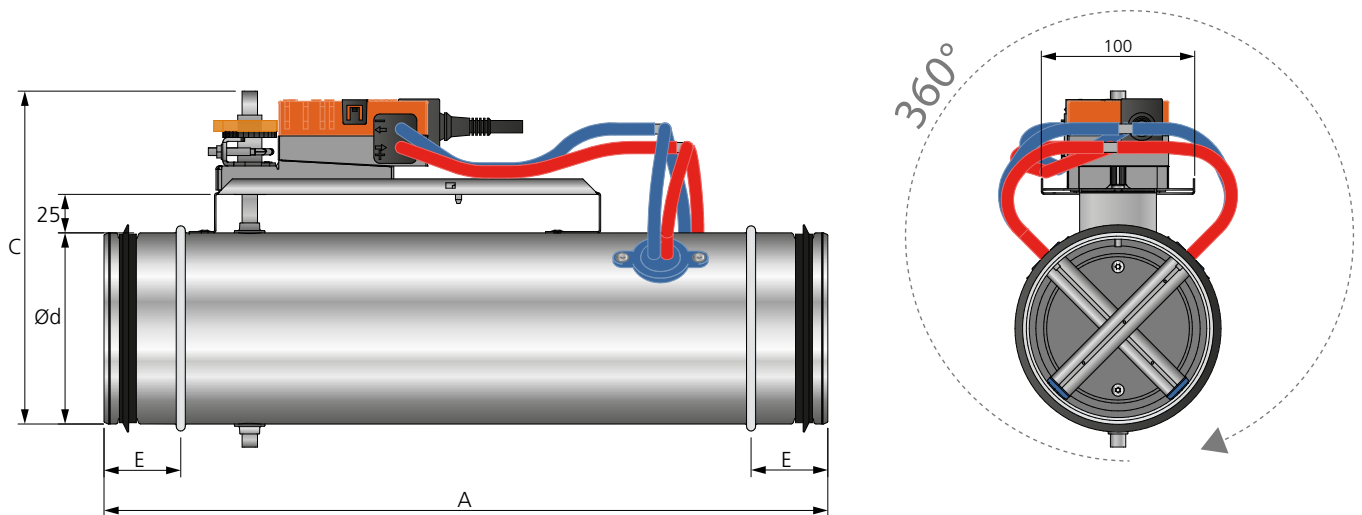

Figure 3. Dimensions (mm), REACT V BBAC circular. The damper can be installed at an optional angle.

Installation

- The product’s air flow measurement requires a straight duct section as per the installation figures.
- In unfavourable conditions before or with disruption, the product’s tolerances cannot be guaranteed.
- Installation is position independent.
- The product can be installed horizontally or vertically.
- Instructions for Use are supplied with the product on delivery, but can also be downloaded from www.swegon.com.

Straight duct section requirements

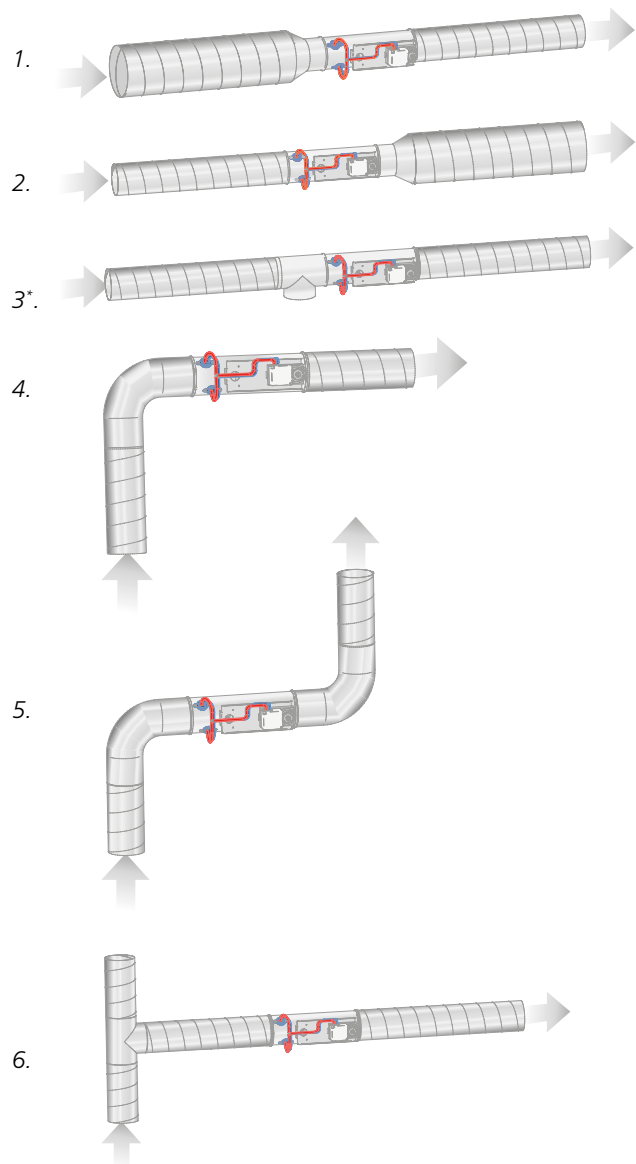

Figure 4. Straight duct section requirements in circular ducts, number of Ø before product:
 Image 1-5 require no straight duct section (image 3* illustrates a T piece with a cleaning hatch).
 Image 6 requires a straight duct section before the damper equivalent to 4 x the diameter of the duct.

Straight duct section requirements in case of sound attenuator with baffle

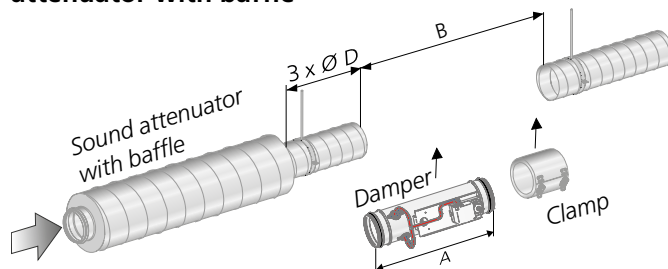

Figure 5. Straight duct section requirements 3 x Ø in case of sound attenuator with baffle or centre body.

Installation in the duct system

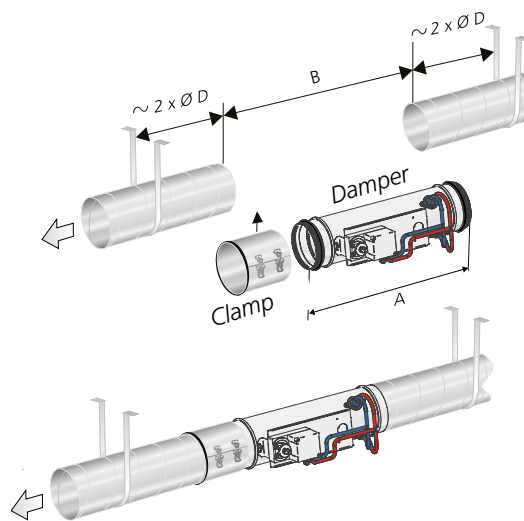

Figure 6. Installation in the duct system. The ducts must be firmly fixed to the frame of the building on each side of the product.

Rectangular design

Dimensions

Size BxH (mm)	Torque (Nm)	Weight (kg)	Flow range						Tolerance Q* ±5% with at least ±x		
			Min.			Max = Vnom ¹⁾			l/s	m³/h	cfm
			l/s	m³/h	cfm	l/s	m³/h	cfm			
200 x 200	5	7.2	67	241	142	365	1314	773	8	29	17
300 x 200	5	8.4	100	360	212	548	1973	1161	12	43	25
400 x 200	5	9.9	133	479	282	730	2628	1547	17	61	36
500 x 200	5	11.4	167	601	354	913	3287	1934	21	76	44
600 x 200	5	12.9	200	720	424	1095	3942	2320	25	90	53
700 x 200	5	14.4	233	839	494	1278	4601	2708	29	104	61
800 x 200	5	15.4	267	961	566	1460	5256	3093	33	119	70
1000 x 200	10	18.7	333	1199	706	1825	6570	3867	42	151	89
300 x 300	5	10.9	152	547	322	834	3002	1767	19	68	40
400 x 300	5	12.4	203	731	430	1112	4003	2356	25	90	53
500 x 300	5	13.9	254	914	538	1390	5004	2945	32	115	68
600 x 300	5	15.4	305	1098	646	1668	6005	3534	38	137	81
700 x 300	10	17.1	355	1278	752	1946	7006	4123	44	158	93
800 x 300	10	18.7	406	1462	860	2224	8006	4712	51	184	108
1000 x 300	10	21.7	508	1829	1076	2780	10008	5890	63	227	133
400 x 400	5	14.0	273	983	578	1495	5382	3168	34	122	72
500 x 400	10	16.3	341	1228	723	1869	6728	3960	43	155	91
600 x 400	10	17.7	409	1472	867	2243	8075	4752	51	184	108
700 x 400	10	19.9	478	1721	1013	2616	9418	5543	60	216	127
800 x 400	10	21.4	546	1966	1157	2990	10764	6335	68	245	144
1000 x 400	10	24.5	682	2455	1445	3738	13457	7920	85	306	180
1200 x 400	20	27.6	819	2948	1735	4485	16146	9503	102	367	216
1400 x 400	20	30.7	955	3438	2023	5233	18839	11088	119	428	252
1600 x 400	20	33.7	1092	3931	2314	5980	21528	12670	136	490	288
500 x 500	10	18.8	429	1544	909	2347	8449	4973	54	194	114
600 x 500	10	20.8	514	1850	1089	2816	10138	5967	64	230	136
700 x 500	10	22.9	600	2160	1271	3286	11830	6962	75	270	159
800 x 500	10	24.9	686	2470	1453	3755	13518	7956	86	310	182
1000 x 500	20	29.0	857	3085	1816	4694	16898	9946	107	385	227
1200 x 500	20	33.1	1028	3701	2178	5633	20279	11935	129	464	273
1400 x 500	20	37.2	1200	4320	2543	6572	23659	13925	150	540	318
1600 x 500	20	41.2	1371	4936	2905	7510	27036	15912	171	616	362
600 x 600	10	23.0	618	2225	1309	3388	12197	7178	77	277	163
700 x 600	10	25.1	722	2599	1530	3952	14227	8373	90	324	191
800 x 600	20	27.2	825	2970	1748	4517	16261	9571	103	371	218
1000 x 600	20	31.3	1031	3712	2184	5646	20326	11963	129	464	273
1200 x 600	20	35.4	1237	4453	2621	6775	24390	14355	155	558	328
1400 x 600	20	39.6	1443	5195	3057	7904	28454	16747	180	648	381
1600 x 600	20	43.8	1649	5936	3494	9033	32519	19139	206	742	436
700 x 700	20	28.0	844	3038	1788	4622	16639	9793	105	378	222
800 x 700	20	30.7	964	3470	2043	5282	19015	11192	121	436	256
1000 x 700	20	35.3	1205	4338	2553	6602	23767	13988	151	544	320
1200 x 700	20	41.0	1446	5206	3064	7923	28523	16787	181	652	384
1400 x 700	20	46.1	1688	6077	3577	9243	33275	19584	211	760	447

¹⁾Vnom at 120 Pa in pressure reading.

*Installed according to the instructions.

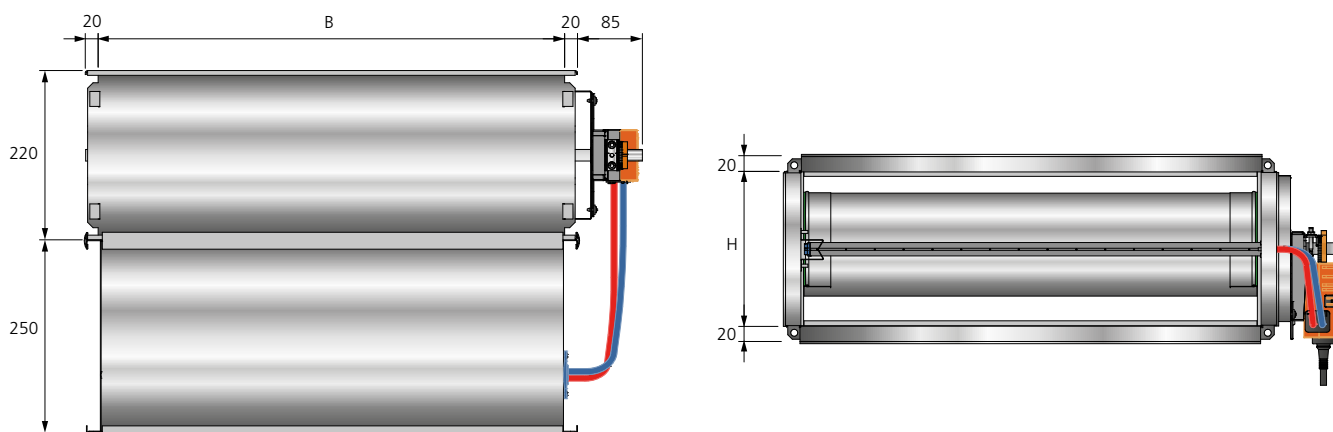

Figure 7. Dimensions (mm), REACT V BBAC rectangular.

Installation

- The product’s air flow measurement requires a straight duct section as per the installation figures.
- In unfavourable conditions before or with disruption, the product’s tolerances cannot be guaranteed.
- Damper spindles must be installed horizontally.
- For rectangular ducts, the damper is always installed so that the controller/actuator is placed along the side of the duct.
- Instructions for Use are supplied with the product on delivery, but can also be downloaded from www.swegon.com.

Straight duct section requirements

Type of disruption	E (m ₂ =5%)	E (m ₂ =10%)
One 90° bend	E = 3 x B	E = 2 x B
T piece	E = 3 x B	E = 2 x B

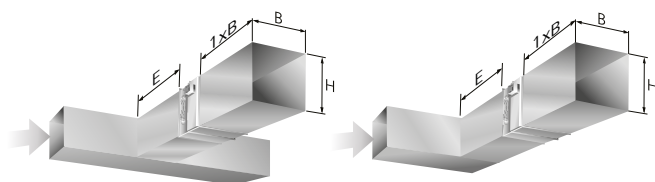

Figure 8. Straight duct section requirements in rectangular ducts.

E = Straight duct section

B = Width of duct

H = Height of duct

Straight duct section requirements in case of sound attenuator with baffle

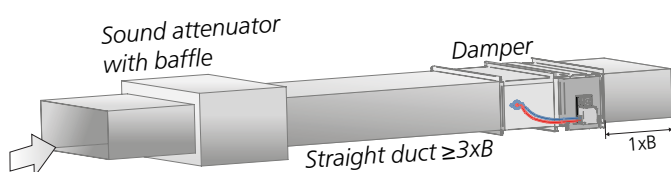

Figure 9. Straight duct section requirements 3 x B in case of sound attenuator with baffle. Applies to both supply and extract air.

Specification

Product

Circular design

Circular variable flow damper REACT V BBAC a bbb

Version:

Size:

100, 125, 160, 200, 250, 315, 400, 500, 630

REACT V BBAC factory setting -

Vmax = Vnom l/s and Vmin = 0 l/s

Rectangular design

Rectangular variable flow damper REACT V BBAC a bbb-ccc

Version:

Size:

Dimension: B x H (see table on page 10)

REACT V BBAC factory setting -

Vmax = Vnom l/s and Vmin = 0 l/s

Accessories

Clamp for circular ventilation ducts FSR c aaa

Version:

Dimension: 100, 125, 160, 200, 250, 315, 400, 500, 630

Cover panel for visible installation REACT V COVER CIRCULAR

For circular design, all sizes

ZTH EU	Hand-held terminal for actuator
LUNA RC	Room controller for temperature regulation
LUNA RC CO ₂	Room controller for temperature regulation and CO ₂
LUNA RE	Room controller for temperature regulation
DETECT IAQ	CO ₂ and temperature controller for room areas
DETECT IAQ OCS	CO ₂ and temperature controller with PIR for room areas
DETECT IAQ D	CO ₂ and temperature controller for ventilation duct
DETECT O V110	Occupancy detector for wall and corner installation
DETECT O T360	Occupancy detector for ceiling installation

