

# REACT

Belimo – Description of functions & wiring diagrams

20231002  
Document version: 1

## Content

<b>Product description</b> .....	3
<b>Air flow control</b>	
<b>Constant flow regulation</b> .....	4
<i>REACT V BMB, REACT V BBAC, REACT V BMP</i>	
<b>Air flow control</b> .....	5
<i>REACT V BMB, REACT V BBAC, REACT V BMP</i>	
<b>Two-flow control with occupancy detector</b> .....	6
<i>REACT V BMB, REACT V BBAC, REACT V BMP   DETECT IAQ, DETECT IAQ D</i>	
<b>Air flow control with temperature and CO<sub>2</sub> function</b> .....	7
<i>REACT V BMB, REACT V BBAC, REACT V BMP   DETECT IAQ, DETECT IAQ D</i>	
<b>Air flow control with temperature, CO<sub>2</sub> and occupancy function</b> .....	8
<i>REACT V BMB, REACT V BBAC, REACT V BMP   DETECT IAQ OCS</i>	
<b>Air flow control with temperature and CO<sub>2</sub> function via external occupancy detector</b> .....	9
<i>REACT V BMB, REACT V BBAC, REACT V BMP   DETECT IAQ, DETECT IAQ D, DETECT IAQ, DETECT IAQ D</i>	
<b>Air flow control with temperature controller for demand control and temperature regulation</b> .....	10
<i>REACT V BMB, REACT V BBAC, REACT V BMP   LUNA RE</i>	
<b>Air flow control with temperature controller for demand control and temperature regulation</b> .....	11
<i>REACT V BMB, REACT V BBAC, REACT V BMP   LUNA RC</i>	
<b>Air flow control with temperature controller for demand control and temperature regulation</b> .....	12
<i>REACT Parasol Zenith   LUNA RC</i>	
<b>Air flow control with temperature and CO<sub>2</sub> controller for demand control and temperature regulation</b> .....	13
<i>REACT Parasol Zenith   LUNA RC CO<sub>2</sub></i>	
<b>Air flow control with temperature and CO<sub>2</sub> controller for demand control and temperature regulation</b> .....	14
<i>REACT V BMB, REACT V BBAC, REACT V BMP   LUNA RC CO<sub>2</sub></i>	
<b>Air flow control with controller for demand control</b> .....	15
<i>REACT V BMB, REACT V BBAC, REACT V BMP</i>	
<b>Air flow control with temperature controller and temperature regulation for demand control via external occupancy sensor</b> .....	16
<i>REACT V BMB, REACT V BBAC, REACT V BMP   DETECT Occupancy, LUNA RE</i>	
<b>Air flow control with controller for demand control via external occupancy sensor</b> .....	17
<i>REACT V BMB, REACT V BBAC, REACT V BMP   DETECT Occupancy</i>	
<b>Air flow control with temperature controller for demand control and absence control</b> .....	18
<i>REACT V BMB, REACT V BBAC, REACT V BMP   LUNA RE, DETECT Occupancy</i>	
<b>Air flow control with demand control via Modbus or BACnet communication</b> .....	19
<i>REACT V BMB, REACT V BBAC, REACT V BMP</i>	
<b>Parallel controlled air flow control</b>	
<b>Parallel controlled air flow control</b> .....	20
<i>REACT V BMB, REACT V BBAC, REACT V BMP</i>	
<b>Parallel controlled two-flow control with occupancy detector</b> .....	21
<i>REACT V BMB, REACT V BBAC, REACT V BMP   DETECT Occupancy</i>	

<b>Parallel controlled air flow control with temperature and CO<sub>2</sub> function .....</b>	<b>22</b>
<i>REACT V BMB, REACT V BBAC, REACT V BMP   DETECT IAQ, DETECT IAQ D</i>	
<b>Parallel controlled air flow control with temperature, CO<sub>2</sub> and occupancy function.....</b>	<b>23</b>
<i>REACT V BMB, REACT V BBAC, REACT V BMP   DETECT IAQ OCS</i>	
<b>Parallel controlled air flow control with temperature and CO<sub>2</sub> function via external occupancy detector ...</b>	<b>24</b>
<i>REACT V BMB, REACT V BBAC, REACT V BMP   DETECT Occupancy, DETECT IAQ, DETECT IAQ D</i>	
<b>Parallel controlled air flow control with temperature controller for demand control and temperature regulation.....</b>	<b>25</b>
<i>REACT V BMB, REACT V BBAC, REACT V BMP   LUNA RE</i>	
<b>Parallel controlled air flow control with controller for demand control .....</b>	<b>26</b>
<i>REACT V BMB, REACT V BBAC, REACT V BMP</i>	
<b>Parallel controlled air flow control with temperature controller and temperature regulation for demand control via external occupancy sensor .....</b>	<b>27</b>
<i>REACT V BMB, REACT V BBAC, REACT V BMP   DETECT Occupancy, LUNA RE</i>	
<b>Parallel controlled air flow control with controller for demand control via external occupancy sensor.....</b>	<b>28</b>
<i>REACT V BMB, REACT V BBAC, REACT V BMP   DETECT Occupancy</i>	
<b>Parallel controlled air flow control with temperature controller for demand control and absence control.....</b>	<b>29</b>
<i>REACT V BMB, REACT V BBAC, REACT V BMP   LUNA RE, DETECT Occupancy</i>	
 <b>Balanced air flow control</b>	
<b>Balanced air flow control.....</b>	<b>30</b>
<i>REACT V BMB, REACT V BBAC, REACT V BMP</i>	
<b>Balanced two-flow control with occupancy detector.....</b>	<b>31</b>
<i>REACT V BMB, REACT V BBAC, REACT V BMP   DETECT Occupancy</i>	
<b>Balanced air flow control with temperature and CO<sub>2</sub> function.....</b>	<b>32</b>
<i>REACT V BMB, REACT V BBAC, REACT V BMP   DETECT IAQ, DETECT IAQ D</i>	
<b>Balanced air flow control with temperature, CO<sub>2</sub> and occupancy function.....</b>	<b>33</b>
<i>REACT V BMB, REACT V BBAC, REACT V BMP   DETECT IAQ OCS</i>	
<b>Balanced air flow control with temperature and CO<sub>2</sub> function via external occupancy detector.....</b>	<b>34</b>
<i>REACT V BMB, REACT V BBAC, REACT V BMP   DETECT Occupancy, DETECT IAQ, DETECT IAQ D</i>	
<b>Balanced air flow control with temperature controller for demand control and temperature regulation....</b>	<b>35</b>
<i>REACT V BMB, REACT V BBAC, REACT V BMP   LUNA RE</i>	
<b>Balanced air flow control with controller for demand control.....</b>	<b>36</b>
<i>REACT V BMB, REACT V BBAC, REACT V BMP</i>	
<b>Balanced air flow control with temperature controller and temperature adjustment for demand control via external occupancy sensor.....</b>	<b>37</b>
<i>REACT V BMB, REACT V BBAC, REACT V BMP   DETECT Occupancy, LUNA RE</i>	
<b>Balanced air flow control with controller for demand control via external occupancy sensor.....</b>	<b>38</b>
<i>REACT V BMB, REACT V BBAC, REACT V BMP   DETECT Occupancy</i>	
<b>Balanced air flow control with temperature controller for demand control and absence control .....</b>	<b>39</b>
<i>REACT V BMB, REACT V BBAC, REACT V BMP   LUNA RE, DETECT Occupancy</i>	

## Product description

### Climate products



**REACT Parasol Zenith**

Comfort module with integrated, pressure independent VAV control.

### Duct mounted products



**REACT V BMB**

Damper for variable or constant flow regulation (Modbus).



**REACT V BBAC**

Damper for variable or constant flow regulation (BACnet).



**REACT V BMP**

Damper for variable or constant flow regulation (MP-bus).

### Room controllers



**DETECT IAQ**

CO<sub>2</sub> and temperature controller (Modbus).



**DETECT IAQ OCS**

CO<sub>2</sub> and temperature controller that also detects occupancy (Modbus).



**DETECT IAQ D**

CO<sub>2</sub> and temperature controller for duct installation (Modbus).



**DETECT Occupancy**

Occupancy detector for ceiling installation.



**LUNA RC**

Room controller for temperature control, with display (Modbus).



**LUNA RC CO<sub>2</sub>**

Room controller for temperature control and CO<sub>2</sub>, with display (Modbus).



**LUNA RE**

Room controller for temperature control (Modbus).



**DETECT Occupancy**

Occupancy detector for wall and corner installation.

# Constant flow regulation

Air flow measurement and regulating damper to maintain the set air flow.

Possibility of Modbus/BACnet communication in combination with analogue control signals.

## Settings

### Air flow regulation

Vmin : Constant flow

Vmax : Nominal flow

Mode : 0 (2)-10 V

Set point source : Analogue

Bus protocol : Modbus alt BACnet

## Wiring diagram

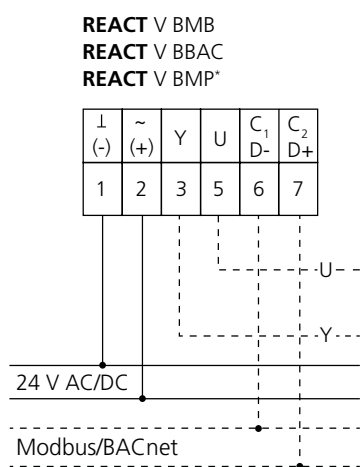

\*Modbus/BACnet communication not available

## Notes

---



---



---



---

# Air flow control

Air flow measurement and regulating damper that variably controls between the minimum and maximum air flow depending on the control signal.

Demand control via analogue control signal (Y). Return of the current air flow via analogue actual value signal (U). Possibility of Modbus/BACnet communication in combination with analogue control signals.

## Settings

### Air flow regulation

Vmin : Minimum air flow

Vmax : Maximum air flow

Mode : 0 (2)-10 V

Set point source : Analogue

Bus protocol : Modbus alt BACnet

## Wiring diagram

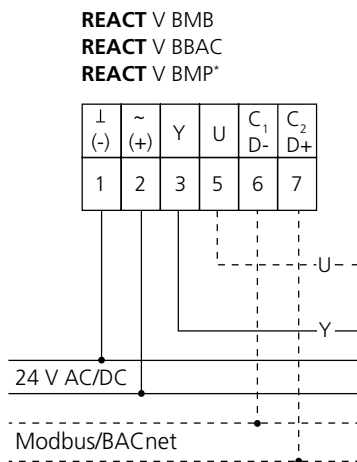

\*Modbus/BACnet communication not available

## Notes

---



---



---



---

## Two-flow control with occupancy detector

Air flow measurement and regulating damper that controls the air flow on the set position. The damper switches via occupancy detection between two fixed flows.

Demand control via analogue control signal (Y). Return of the current air flow via analogue actual value signal (U). Possibility of Modbus/BACnet communication in combination with analogue control signals.

### Settings

#### Air flow regulation

Vmin : Unoccupied flow

Vmax : Occupancy flow

Mode : 0 (2)-10 V

Set point source : Analogue

Bus protocol : Modbus alt BACnet

### Wiring diagram

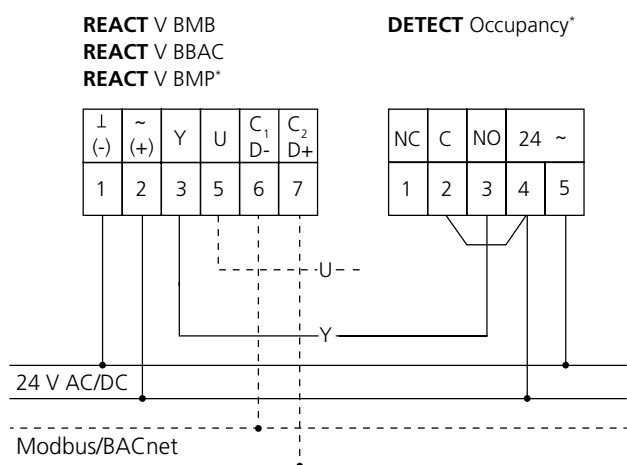

\*Modbus/BACnet communication not available

### Notes

---



---



---



---

# Air flow control with temperature and CO<sub>2</sub> function

Air flow measurement and regulating damper that variably controls between the minimum and maximum air flow depending on the current temperature and the CO<sub>2</sub> content in the room.

Demand control via analogue control signal (Y). Return of the current air flow via analogue actual value signal (U). Possibility of Modbus/BACnet communication in combination with analogue control signals.

## Settings

### Air flow regulation

Vmin : Minimum air flow

Vmax : Maximum air flow

Mode : 0 - 10 V

Set point source : Analogue

Bus protocol : Modbus alt BACnet

## Wiring diagram

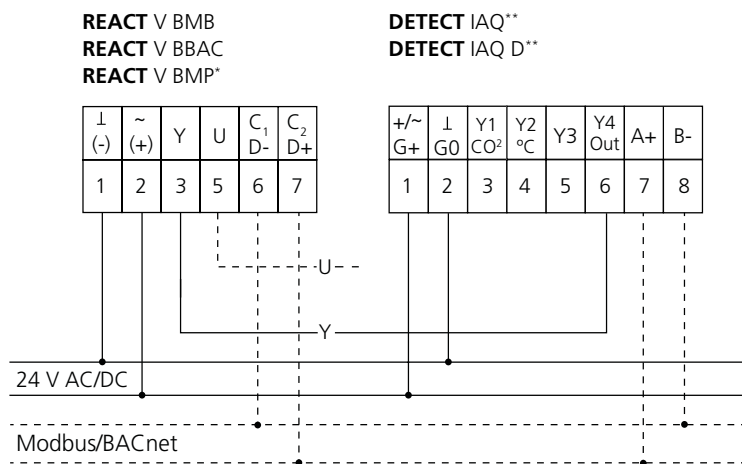

\*Modbus/BACnet communication not available

\*\*BACnet communication not available

## Notes

---



---



---



---

# Air flow control with temperature, CO<sub>2</sub> and occupancy function

Air flow measurement and regulating damper that variably controls the air flow between the minimum and maximum flow rate depending on the current temperature and the CO<sub>2</sub> content in occupancy mode. Occupancy is detected via internal occupancy sensor. The damper is regulated to minimum flow rate in no-occupancy mode.

Demand control via analogue control signal (Y). Return of the current air flow via analogue actual value signal (U). Possibility of Modbus/BACnet communication in combination with analogue control signals.

## Settings

### Air flow regulation

Vmin : Minimum air flow

Vmax : Maximum air flow

Mode : 0 - 10 V

Set point source : Analogue

Bus protocol : Modbus alt BACnet

## Wiring diagram

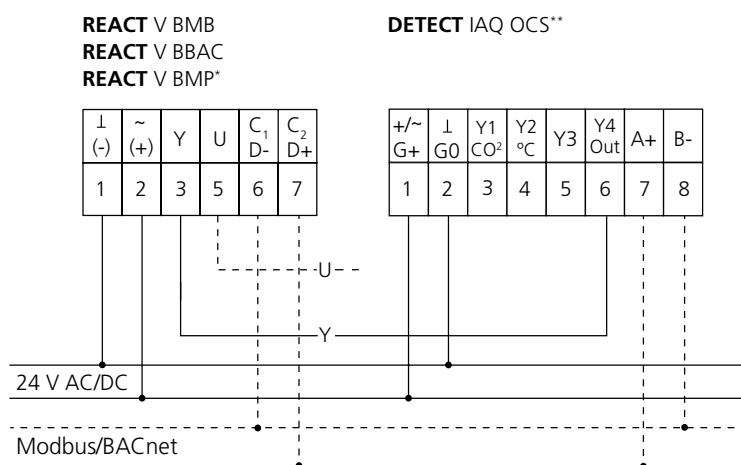

\*Modbus/BACnet communication not available

\*\*BACnet communication not available

## Notes

---



---



---



---



# Air flow control with temperature and CO<sub>2</sub> function via external occupancy detector

Air flow measurement and regulating damper that variably controls the air flow between the minimum and maximum flow rate depending on the current temperature and the CO<sub>2</sub> content in occupancy mode. Occupancy is detected via external occupancy sensor. The damper is regulated to minimum flow rate in no-occupancy mode.

Demand control via analogue control signal (Y). Return of the current air flow via analogue actual value signal (U). Possibility of Modbus/BACnet communication in combination with analogue control signals.

## Settings

### Air flow regulation

Vmin : Minimum air flow

Vmax : Maximum air flow

Mode : 0 - 10 V

Set point source : Analogue

Bus protocol : Modbus alt BACnet

## Wiring diagram

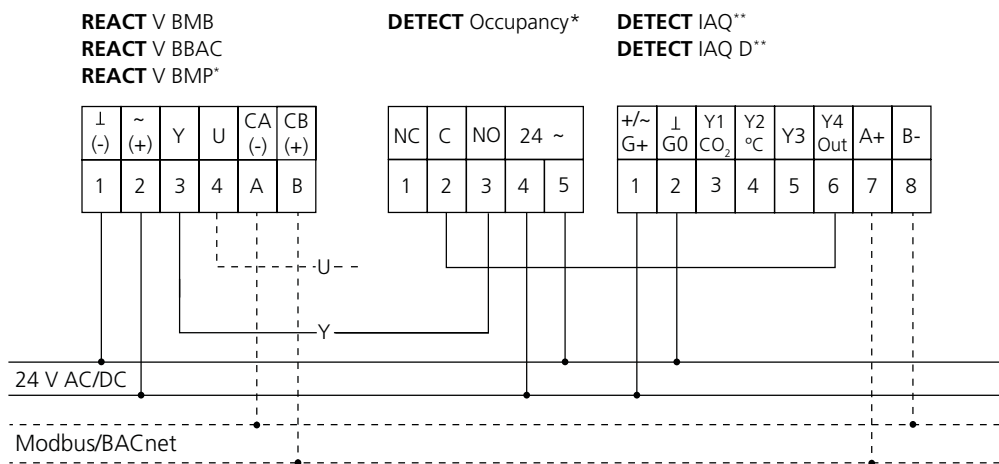

\*Modbus/BACnet communication not available

\*\*BACnet communication not available

## Notes

---



---



---



---

# Air flow control with temperature controller for demand control and temperature regulation

Air flow measurement and regulating damper that variably controls between the set minimum and maximum flow rate (cooling function) depending on the set temperature set point. The wiring diagram also shows the alternative with RTCT duct temperature sensor and thermo-actuator (Ts) for heating function.

Demand control via analogue control signal (Y). Return of the current air flow via analogue actual value signal (U). Possibility of Modbus/BACnet communication in combination with analogue control signals.

## Settings

### Air flow regulation

Vmin : Minimum air flow

Vmax : Maximum air flow

Mode : 0 (2)-10 V

Set point source : Analogue

Bus protocol : Modbus alt BACnet

## Wiring diagram

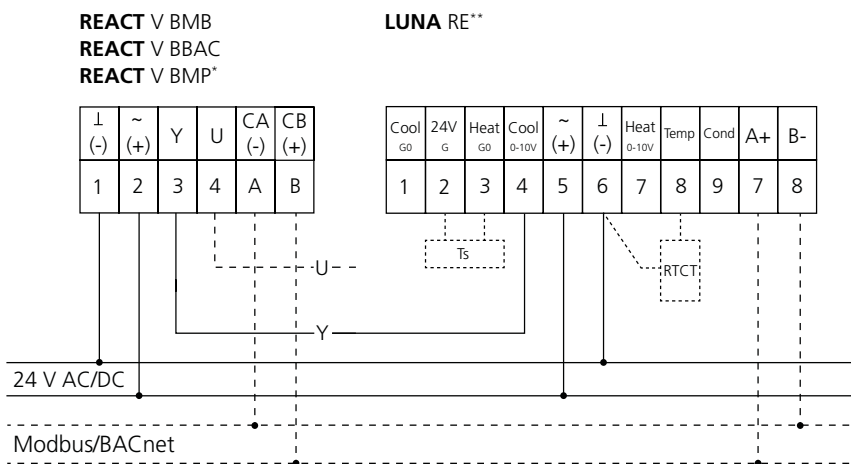

\*Modbus/BACnet communication not available  
 \*\*BACnet communication not available

## Notes

---



---



---



---

# Air flow control with temperature controller for demand control and temperature regulation

Air flow measurement and regulating damper that variably controls between the set minimum and maximum flow rate (cooling function) depending on the set temperature set point. Control of thermo-actuators for cooling/heating.

Demand control via analogue control signal (Y). Return of the current air flow via analogue actual value signal (U). Possibility of Modbus/BACnet communication in combination with analogue control signals.

## Settings

### Air flow regulation

Vmin : Minimum air flow

Vmax : Maximum air flow

Mode : 0 - 10 V

Set point source : Analogue

Bus protocol : Modbus alt BACnet

## Wiring diagram

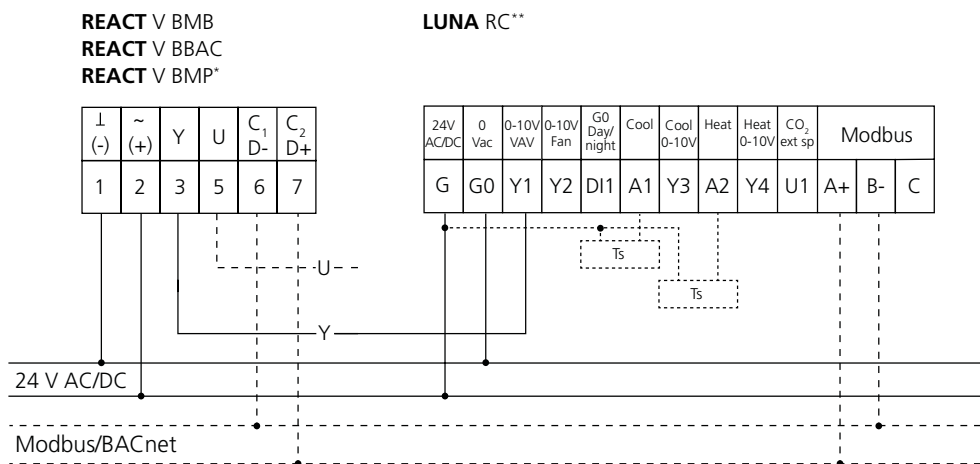

\*Modbus/BACnet communication not available

\*\*BACnet communication not available

## Notes

---



---



---



---

# Air flow control with temperature controller for demand control and temperature regulation

Air flow measurement and regulating damper that variably controls between the set minimum and maximum flow rate (cooling function) depending on the set temperature set point. Control of thermo-actuators for cooling/heating.

Demand control via analogue control signal (Y). Return of the current air flow via analogue actual value signal (U). Potential to connect condensation sensor.

Possibility of Modbus/BACnet communication in combination with analogue control signals.

## Settings

### Air flow regulation

Vmin : Minimum air flow

Vmax : Maximum air flow

Mode : 0 - 10 V

Set point source : Analogue

Bus protocol : Modbus alt BACnet

## Wiring diagram

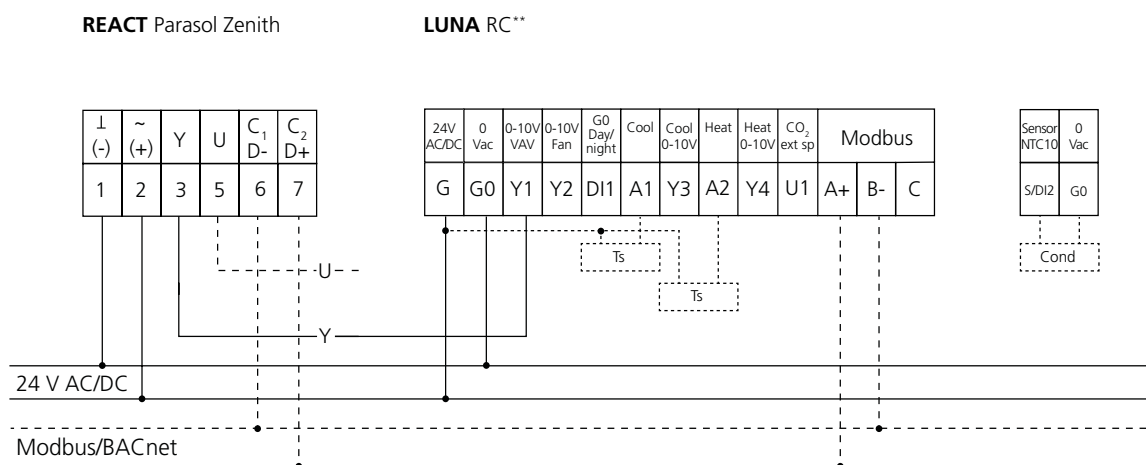

\*\*BACnet communication not available

## Notes

---



---



---



---

# Air flow control with temperature and CO<sub>2</sub> controller for demand control and temperature regulation

Air flow measurement and regulating damper that variably controls between the minimum and maximum flow rate depending on the set temperature set point (cooling function) and the CO<sub>2</sub> content in the room. Control of thermo-actuators for cooling/heating.

Demand control via analogue control signal (Y). Return of the current air flow via analogue actual value signal (U). Potential to connect condensation sensor.

Possibility of Modbus/BACnet communication in combination with analogue control signals.

## Settings

### Air flow regulation

Vmin : Minimum air flow

Vmax : Maximum air flow

Mode : 0 - 10 V

Set point source : Analogue

Bus protocol : Modbus alt BACnet

## Wiring diagram

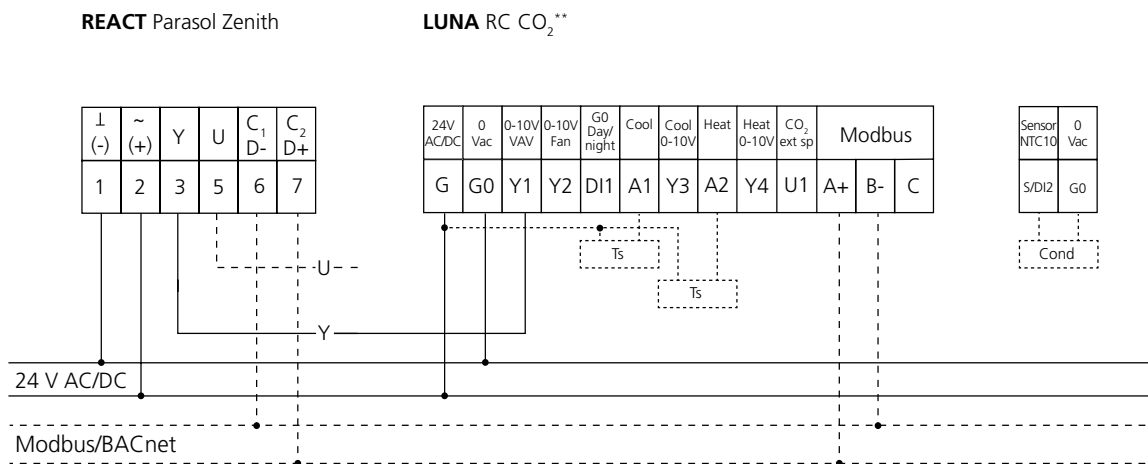

\*\*BACnet communication not available

## Notes

---



---



---



---

# Air flow control with temperature and CO<sub>2</sub> controller for demand control and temperature regulation

Air flow measurement and regulating damper that variably controls between the minimum and maximum flow rate depending on the set temperature set point (cooling function) and the CO<sub>2</sub> content in the room. Control of thermo-actuators for cooling/heating.

Demand control via analogue control signal (Y). Return of the current air flow via analogue actual value signal (U). Possibility of Modbus/BACnet communication in combination with analogue control signals.

## Settings

### Air flow regulation

Vmin : Minimum air flow

Vmax : Maximum air flow

Mode : 0 - 10 V

Set point source : Analogue

Bus protocol : Modbus alt BACnet

## Wiring diagram

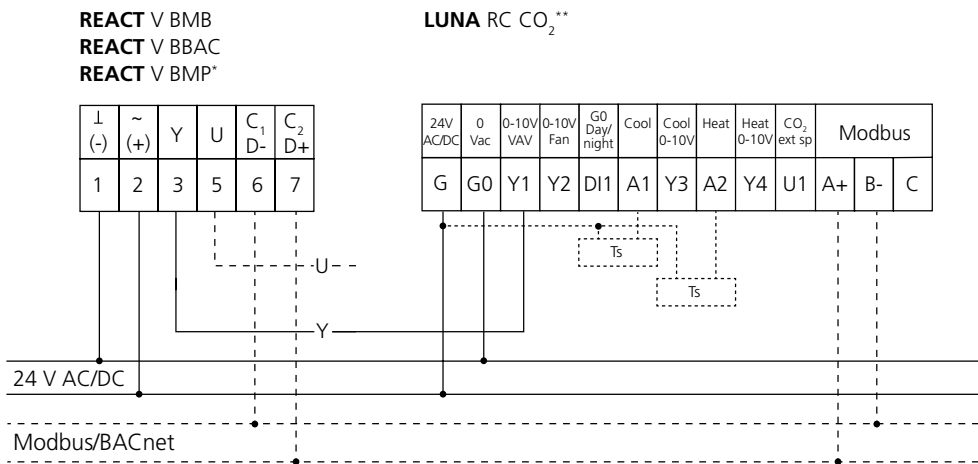

\*Modbus/BACnet communication not available  
 \*\*BACnet communication not available

## Notes

---



---



---



---

# Air flow control with controller for demand control

Air flow measurement and regulating damper that variably controls between the minimum and maximum flow rate depending on the control signal.

Demand control via analogue control signal (Y). Return of the current air flow via analogue actual value signal (U). Possibility of Modbus/BACnet communication in combination with analogue control signals.

## Settings

### Air flow regulation

Vmin : Minimum air flow

Vmax : Maximum air flow

Mode : 0 (2)-10 V

Set point source : Analogue

Bus protocol : Modbus alt BACnet

## Wiring diagram

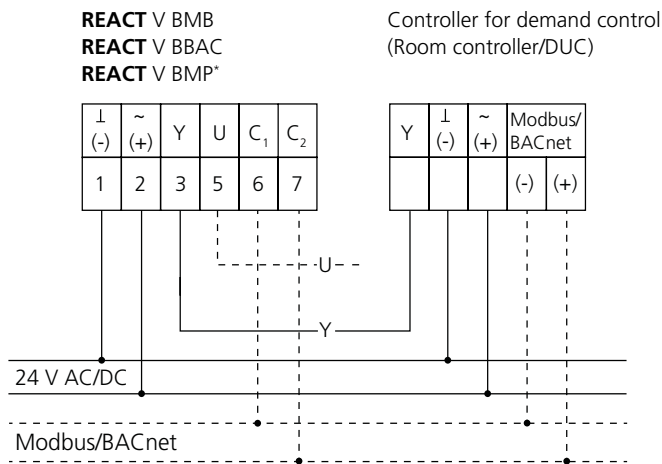

\*Modbus/BACnet communication not available

## Notes

---



---



---



---

# Air flow control with temperature controller and temperature regulation for demand control via external occupancy sensor

Air flow measurement and regulating damper that variably controls between the set minimum and maximum flow rate (cooling function) depending on the set temperature set point in occupancy mode. Occupancy is detected via external occupancy sensor. The room is regulated to minimum flow rate in no-occupancy mode. The wiring diagram also shows the alternative with RTCT duct temperature sensor and thermo-actuator (Ts) for heating function.

Demand control via analogue control signal (Y). Return of the current air flow via analogue actual value signal (U). Possibility of Modbus/BACnet communication in combination with analogue control signals.

## Settings

### Air flow regulation

Vmin : Minimum air flow

Vmax : Maximum air flow

Mode : 0 (2)-10 V

Set point source : Analogue

Bus protocol : Modbus alt BACnet

## Wiring diagram

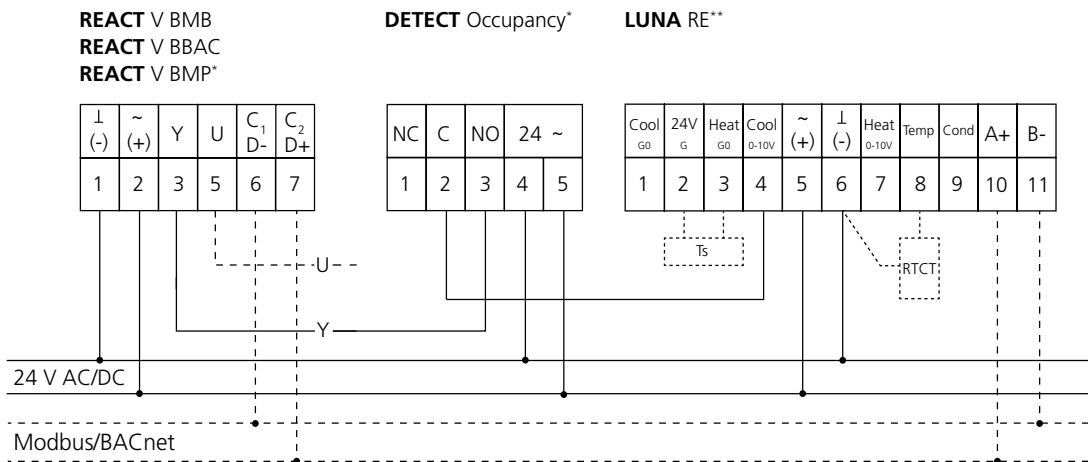

\*Modbus/BACnet communication not available

\*\*BACnet communication not available

## Notes

---



---



---



---



# Air flow control with controller for demand control via external occupancy sensor

Air flow measurement and regulating damper that variably controls between the minimum and maximum flow rate depending on the control signal in occupancy mode. Occupancy is detected via external occupancy sensor. The room is regulated to minimum flow rate in no-occupancy mode.

Demand control via analogue control signal (Y). Return of the current air flow via analogue actual value signal (U). Possibility of Modbus/BACnet communication in combination with analogue control signals.

## Settings

### Air flow regulation

Vmin : Minimum air flow

Vmax : Maximum air flow

Mode : 0 (2)-10 V

Set point source : Analogue

Bus protocol : Modbus alt BACnet

## Wiring diagram

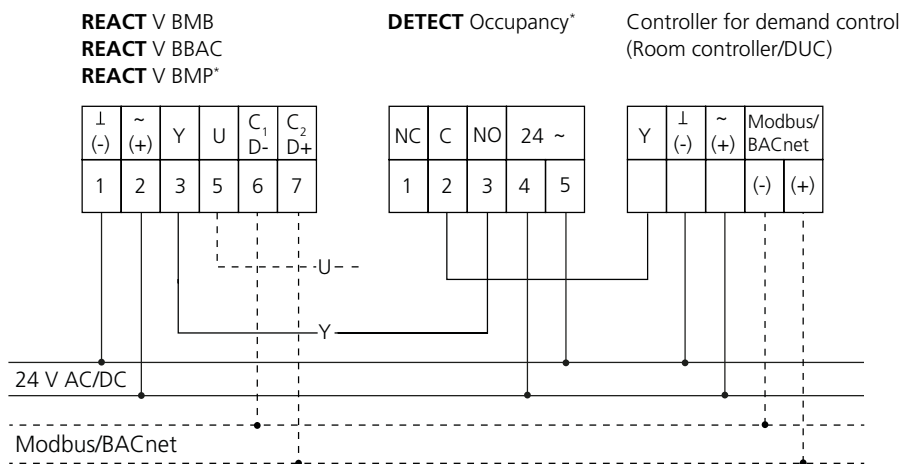

\*Modbus/BACnet communication not available

## Notes

---



---



---



---

# Air flow control with temperature controller for demand control and absence control

Air flow measurement and regulating damper that variably controls between the set minimum and maximum flow rate (cooling function) depending on the set temperature set point in occupancy mode. The room is set to absence temperature set point in no-occupancy mode. The wiring diagram also shows the alternative with RTCT duct temperature sensor and thermo-actuator (Ts) for heating function.

Demand control via analogue control signal (Y). Return of the current air flow via analogue actual value signal (U). Possibility of Modbus/BACnet communication in combination with analogue control signals.

## Settings

### Air flow regulation

Vmin : Minimum air flow

Vmax : Maximum air flow

Mode : 0 - 10 V

Set point source : Analogue

Bus protocol : Modbus alt BACnet

## Wiring diagram

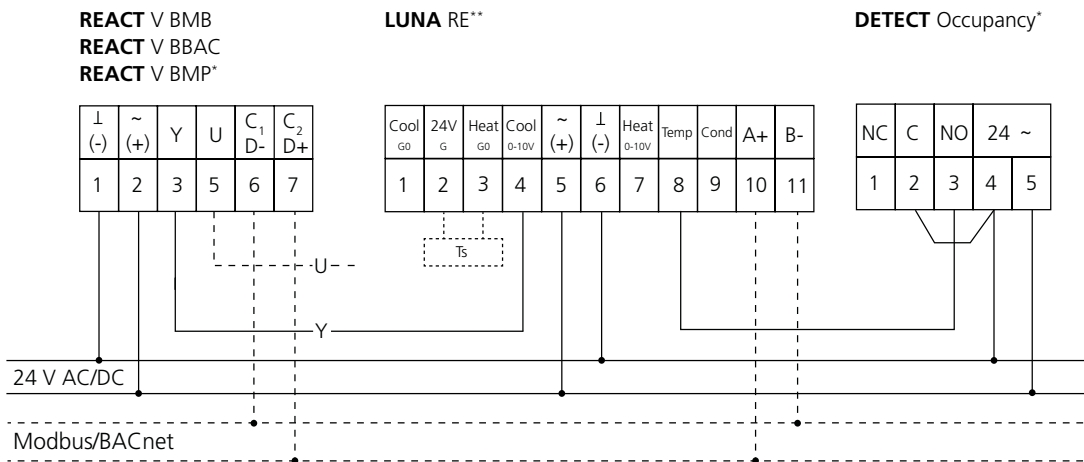

\*Modbus/BACnet communication not available

\*\*BACnet communication not available

## Notes

---



---



---

# Air flow control with demand control via Modbus or BACnet communication

Air flow measurement and regulating damper that variably controls between the minimum and maximum flow rate depending on the set demand.

Demand control via Modbus/BACnet communication.

## Settings

### Air flow regulation

Vmin : Minimum air flow

Vmax : Maximum air flow

Set point source : Analogue

Bus protocol : Modbus alt BACnet

### BACnet

Set point source, SpSource (MV[122]) : 2

Set point, SpRel (MO[1]) : 0...10000  
0 = 0% (min. flow), 10000 = 100% (max. flow)

For more information, see BACnet documentation for REACT Belimo.

### Modbus

Set point source (Address 118) : 1

Setpoint (Address 0) : 0...10000  
0 = 0% (min. flow), 10000 = 100% (max. flow)

For more information, see Modbus documentation for REACT Belimo.

## Wiring diagram

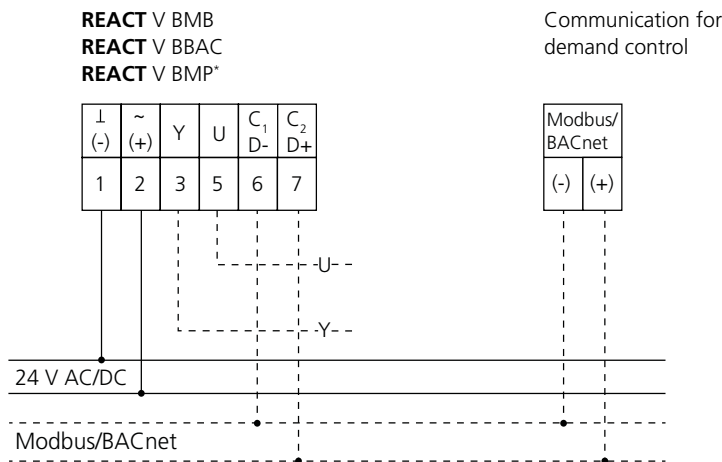

\*Modbus/BACnet communication not available

## Notes

---



---



---



---

## Parallel controlled air flow control

Air flow measurement and regulating damper that variably controls the air flow in parallel between minimum and maximum flow rate depending on the control signal.

Demand control via analogue control signal (Y). Return of the current air flow via analogue actual value signal (U). Possibility of Modbus/BACnet communication in combination with analogue control signals.

### Settings

#### Air flow regulation

Vmin : Minimum air flow

Vmax : Maximum air flow

Mode : 0 (2)-10 V

Set point source : Analogue

Bus protocol : Modbus alt BACnet

### Wiring diagram

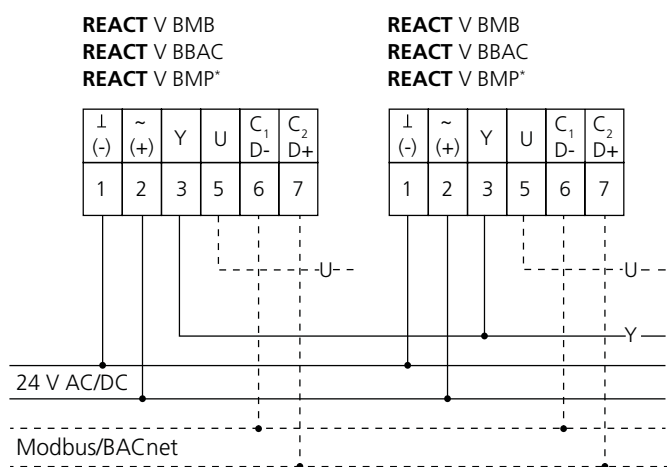

\*Modbus/BACnet communication not available

### Notes

---



---



---



---

# Parallel controlled two-flow control with occupancy detector

Air flow measurement and regulating damper that controls the air flow on the set position. Via occupancy detection, the dampers switch between unoccupied and occupancy flow.

Demand control via analogue control signal (Y). Return of the current air flow via analogue actual value signal (U). Possibility of Modbus/BACnet communication in combination with analogue control signals.

## Settings

### Air flow regulation

Vmin : Unoccupied flow

Vmax : Occupancy flow

Mode : 0 (2)-10 V

Set point source : Analogue

Bus protocol : Modbus alt BACnet

## Wiring diagram

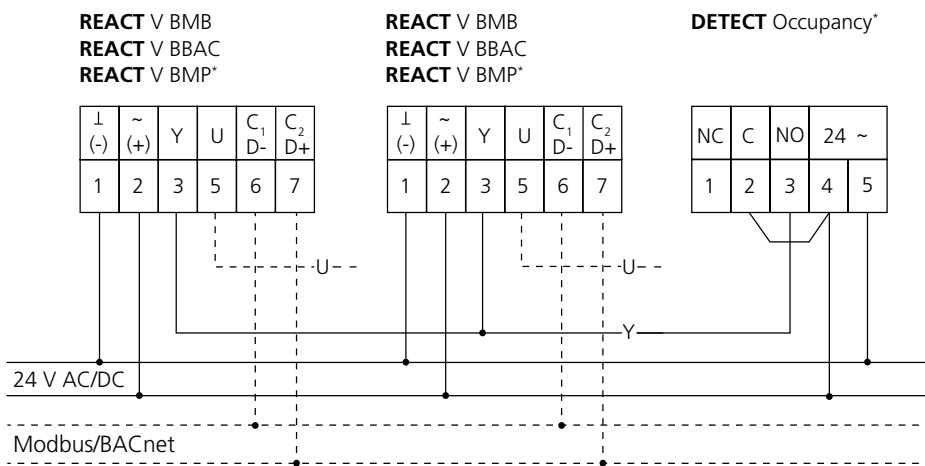

\*Modbus/BACnet communication not available

## Notes

---



---



---



---

# Parallel controlled air flow control with temperature and CO<sub>2</sub> function

Air flow measurement and regulating damper that variably controls the air flow in parallel between the minimum and maximum air flow depending on the current temperature and the CO<sub>2</sub> content in the room.

Demand control via analogue control signal (Y). Return of the current air flow via analogue actual value signal (U). Possibility of Modbus/BACnet communication in combination with analogue control signals.

## Settings

### Air flow regulation

Vmin : Minimum air flow

Vmax : Maximum air flow

Mode : 0 - 10 V

Set point source : Analogue

Bus protocol : Modbus alt BACnet

## Wiring diagram

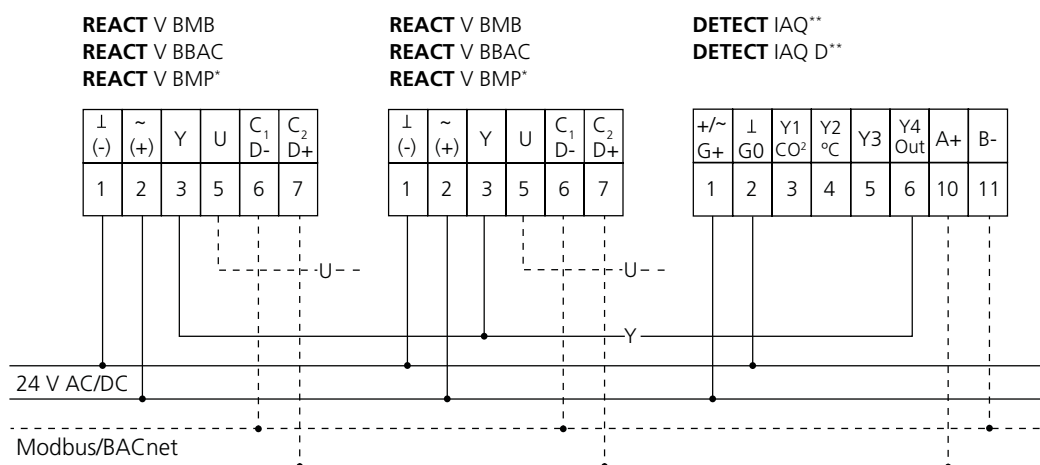

\*Modbus/BACnet communication not available

\*\*BACnet communication not available

## Notes

---



---



---



---

# Parallel controlled air flow control with temperature, CO<sub>2</sub> and occupancy function

Air flow measurement and regulating damper that variably controls the air flow in parallel between the minimum and maximum flow rate depending on the current temperature and the CO<sub>2</sub> content in occupancy mode. Occupancy is detected via internal occupancy sensor. The damper is regulated to minimum flow rate in no-occupancy mode.

Demand control via analogue control signal (Y). Return of the current air flow via analogue actual value signal (U). Possibility of Modbus/BACnet communication in combination with analogue control signals.

## Settings

### Air flow regulation

Vmin : Minimum air flow

Vmax : Maximum air flow

Mode : 0 - 10 V

Set point source : Analogue

Bus protocol : Modbus alt BACnet

## Wiring diagram

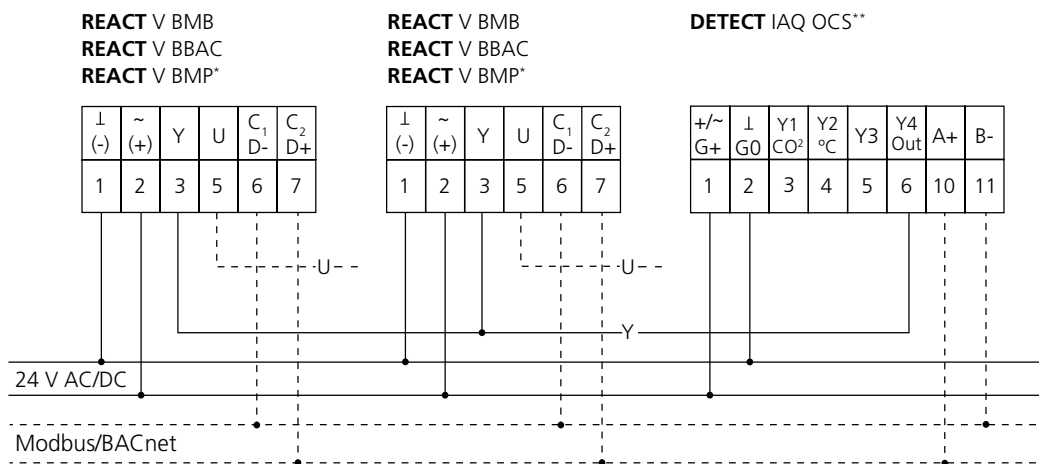

\*Modbus/BACnet communication not available  
 \*\*BACnet communication not available

## Notes

---



---



---

# Parallel controlled air flow control with temperature and CO<sub>2</sub> function via external occupancy detector

Air flow measurement and regulating damper that variably controls the air flow in parallel between the minimum and maximum flow rate depending on the current temperature and the CO<sub>2</sub> content in occupancy mode. Occupancy is detected via external occupancy sensor. The damper is regulated to minimum flow rate in no-occupancy mode.

Demand control via analogue control signal (Y). Return of the current air flow via analogue actual value signal (U). Possibility of Modbus/BACnet communication in combination with analogue control signals.

## Settings

### Air flow regulation

Vmin : Minimum air flow

Vmax : Maximum air flow

Mode : 0 - 10 V

Set point source : Analogue

Bus protocol : Modbus alt BACnet

## Wiring diagram

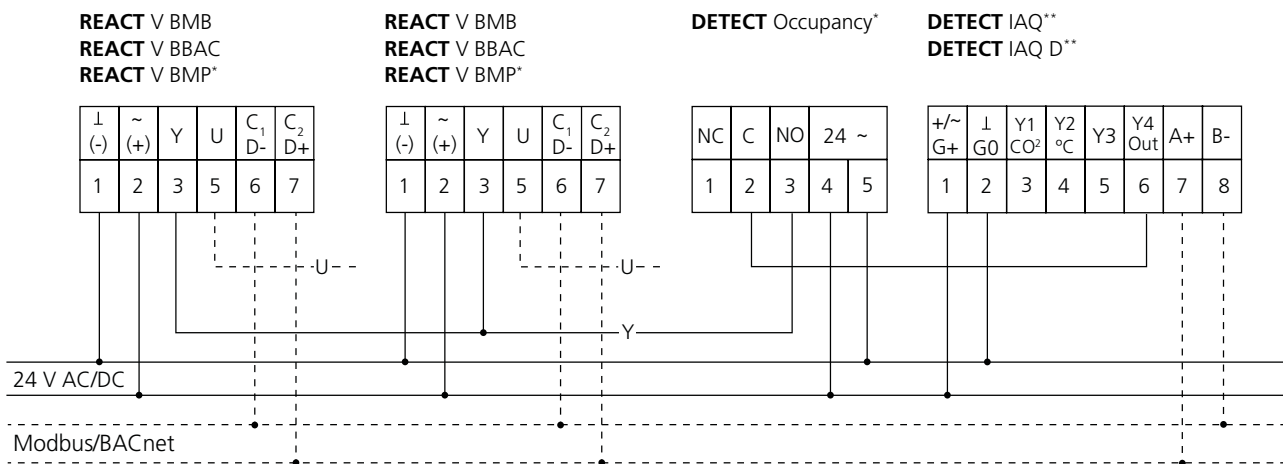

\*Modbus/BACnet communication not available

\*\*BACnet communication not available

## Notes

---



---



---



# Parallel controlled air flow control with temperature controller for demand control and temperature regulation

Air flow measurement and regulating damper that variably controls the air flow in parallel between the minimum and maximum flow rate (cooling function) depending on the set temperature set point. The wiring diagram also shows the alternative with RTCT duct temperature sensor and thermo-actuator (Ts) for heating function.

Demand control via analogue control signal (Y). Return of the current air flow via analogue actual value signal (U). Possibility of Modbus/BACnet communication in combination with analogue control signals.

## Settings

### Air flow regulation

Vmin : Minimum air flow

Vmax : Maximum air flow

Mode : 0 - 10 V

Set point source : Analogue

Bus protocol : Modbus alt BACnet

## Wiring diagram

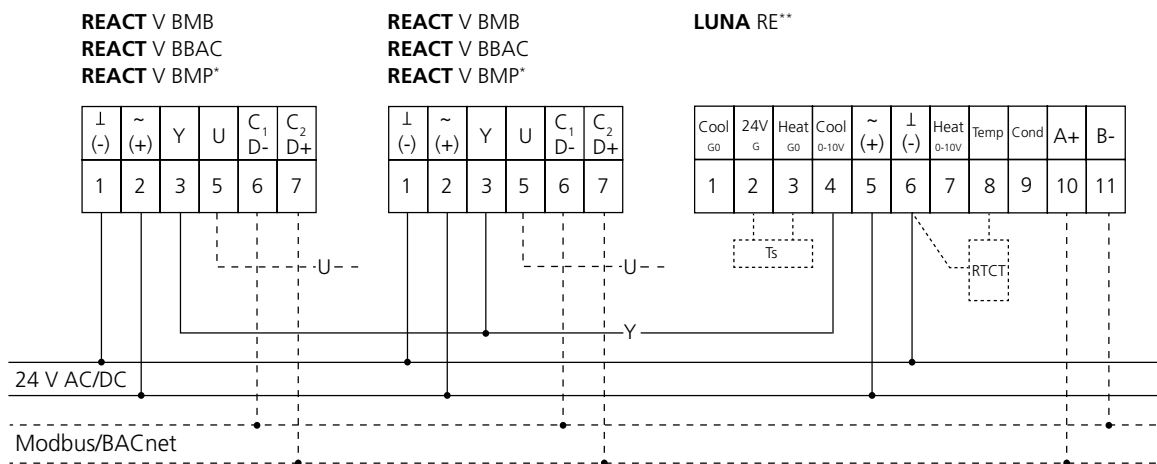

\*Modbus/BACnet communication not available

\*\*BACnet communication not available

## Notes

---



---



---



---

# Parallel controlled air flow control with controller for demand control

Air flow measurement and regulating damper that variably controls the air flow in parallel between minimum and maximum flow rate depending on the control signal.

Demand control via analogue control signal (Y). Return of the current air flow via analogue actual value signal (U). Possibility of Modbus/BACnet communication in combination with analogue control signals.

## Settings

### Air flow regulation

Vmin : Minimum air flow

Vmax : Maximum air flow

Mode : 0 (2)-10 V

Set point source : Analogue

Bus protocol : Modbus alt BACnet

## Wiring diagram

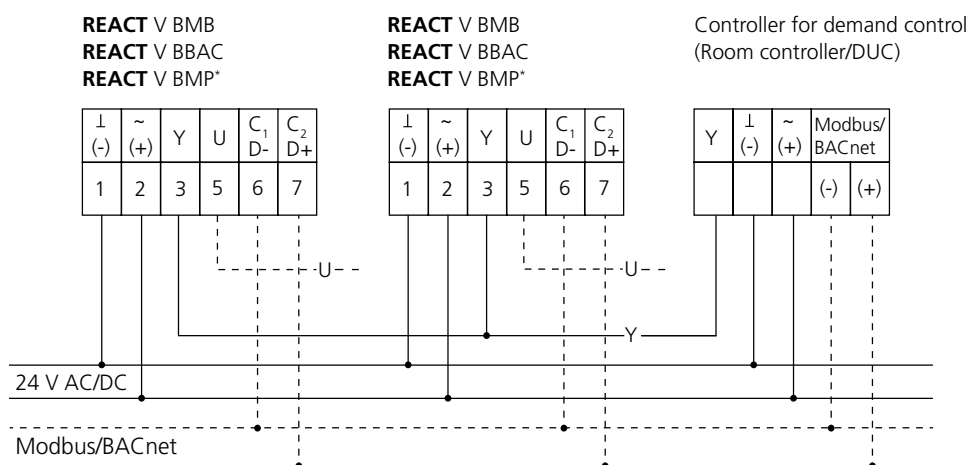

\*Modbus/BACnet communication not available

## Notes

---



---



---



---

# Parallel controlled air flow control with temperature controller and temperature regulation for demand control via external occupancy sensor

Air flow measurement and regulating damper that variably controls the air flow in parallel between the set minimum and maximum flow rate (cooling function) depending on the temperature set point in occupancy mode. Occupancy is detected via external occupancy sensor. The room is regulated to minimum flow rate in no-occupancy mode. The wiring diagram also shows the alternative with RTCT duct temperature sensor and thermo-actuator (Ts) for heating function.

Demand control via analogue control signal (Y). Return of the current air flow via analogue actual value signal (U). Possibility of Modbus/BACnet communication in combination with analogue control signals.

## Settings

### Air flow regulation

Vmin : Minimum air flow

Vmax : Maximum air flow

Mode : 0 - 10 V

Set point source : Analogue

Bus protocol : Modbus alt BACnet

## Wiring diagram

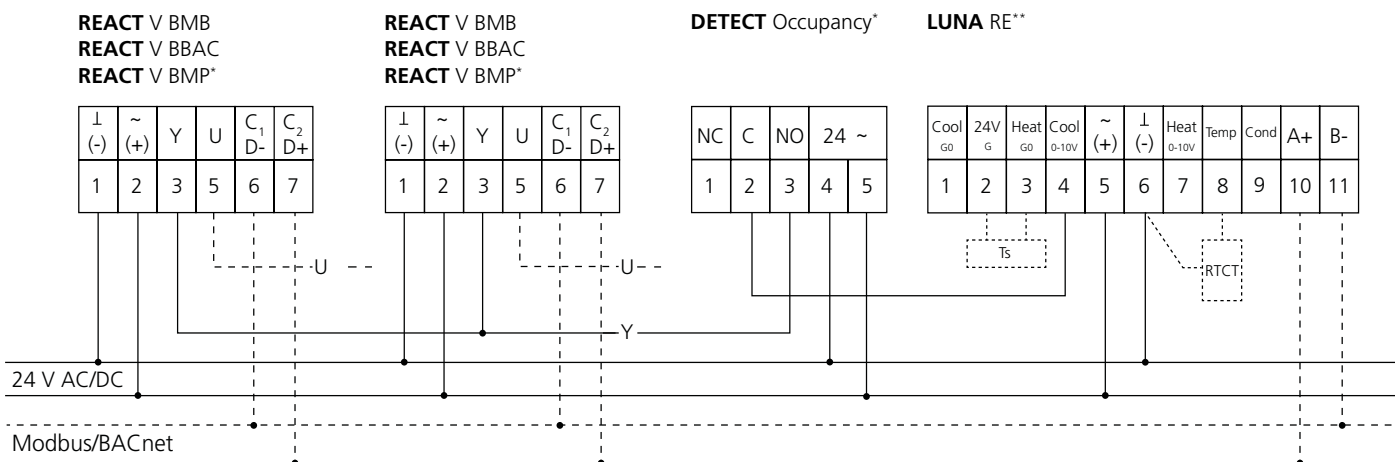

\*Modbus/BACnet communication not available

\*\*BACnet communication not available

## Notes

---



---



---



---

# Parallel controlled air flow control with controller for demand control via external occupancy sensor

Air flow measurement and regulating damper that variably controls the air flow in parallel between minimum and maximum flow rate depending on the control signal in occupancy mode. Occupancy is detected via external occupancy sensor. The room is regulated to minimum flow rate in no-occupancy mode.

Demand control via analogue control signal (Y). Return of the current air flow via analogue actual value signal (U). Possibility of Modbus/BACnet communication in combination with analogue control signals.

## Settings

### Air flow regulation

Vmin : Minimum air flow

Vmax : Maximum air flow

Mode : 0 (2)-10 V

Set point source : Analogue

Bus protocol : Modbus alt BACnet

## Wiring diagram

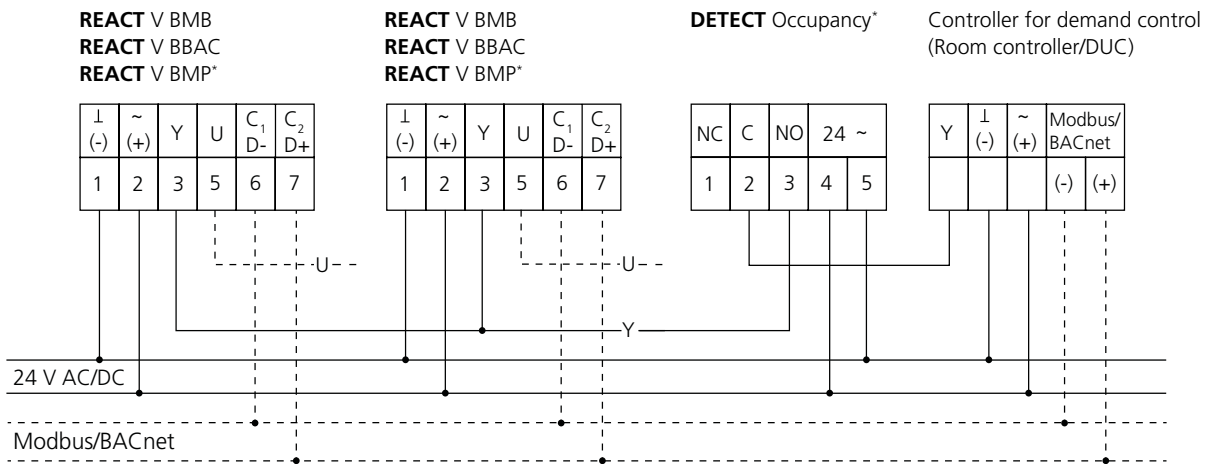

\*Modbus/BACnet communication not available

## Notes

---



---



---



---

# Parallel controlled air flow control with temperature controller for demand control and absence control

Air flow measurement and regulating damper that variably controls the air flow in parallel between the set minimum and maximum flow rate (cooling function) depending on the temperature set point in occupancy mode. The room is set to absence temperature set point in no-occupancy mode. The wiring diagram also shows the alternative with RTCT duct temperature sensor and thermo-actuator (Ts) for heating function.

Demand control via analogue control signal (Y). Return of the current air flow via analogue actual value signal (U). Possibility of Modbus/BACnet communication in combination with analogue control signals.

## Settings

### Air flow regulation

Vmin : Minimum air flow

Vmax : Maximum air flow

Mode : 0 - 10 V

Set point source : Analogue

Bus protocol : Modbus alt BACnet

## Wiring diagram

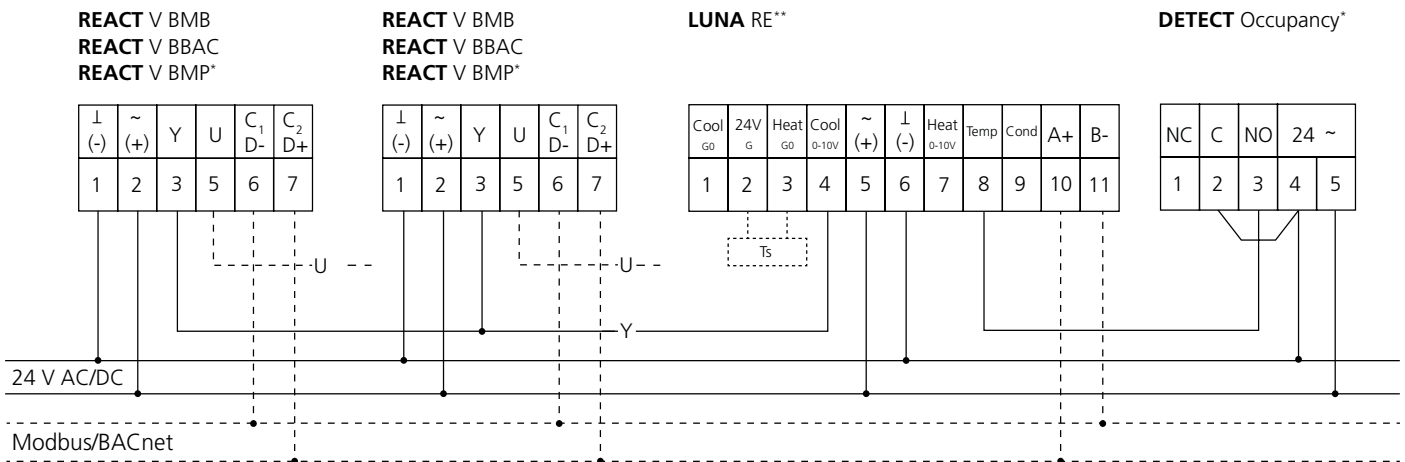

\*Modbus/BACnet communication not available

\*\*BACnet communication not available

## Notes

---



---



---



---

## Balanced air flow control

Air flow measurement and regulating damper that variably controls between the minimum and maximum flow rate depending on the control signal. The air flow value from the master damper is sent analogously to the slave damper to maintain the balance in the room.

Demand control via analogue control signal (Y). Return of the current air flow via analogue actual value signal (U). Possibility of Modbus/BACnet communication in combination with analogue control signals.

### Settings

#### Air flow regulation – Slave

Vmin : 0  
 Vmax : Vnom on Master  
 Mode : Same as Master  
 Set point source : Analogue  
 Bus protocol : Modbus alt BACnet

#### Air flow regulation – Master

Vmin : Minimum air flow  
 Vmax : Maximum air flow  
 Mode : 0 (2)-10 V  
 Set point source : Analogue  
 Bus protocol : Modbus alt BACnet

### Wiring diagram

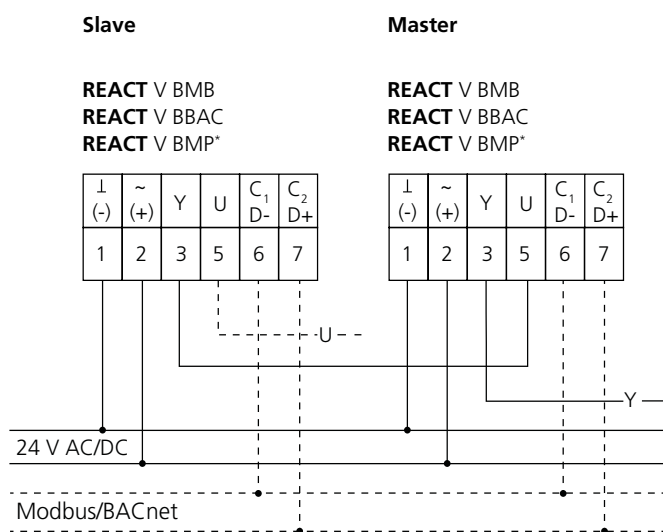

\*Modbus/BACnet communication not available

### Notes

---



---



---



---

# Balanced two-flow control with occupancy detector

Air flow measurement and regulating damper that controls the air flow on the set position. The damper switches via occupancy detection between two fixed flows. The air flow value from the master damper is sent analogously to the slave damper to maintain the balance in the room.

Demand control via analogue control signal (Y). Return of the current air flow via analogue actual value signal (U). Possibility of Modbus/BACnet communication in combination with analogue control signals.

## Settings

### Air flow regulation – Slave

- Vmin : 0
- Vmax : Vnom on Master
- Mode : Same as Master
- Set point source : Analogue
- Bus protocol : Modbus alt BACnet

### Air flow regulation – Master

- Vmin : Unoccupied flow
- Vmax : Occupancy flow
- Mode : 0 (2)-10 V
- Set point source : Analogue
- Bus protocol : Modbus alt BACnet

## Wiring diagram

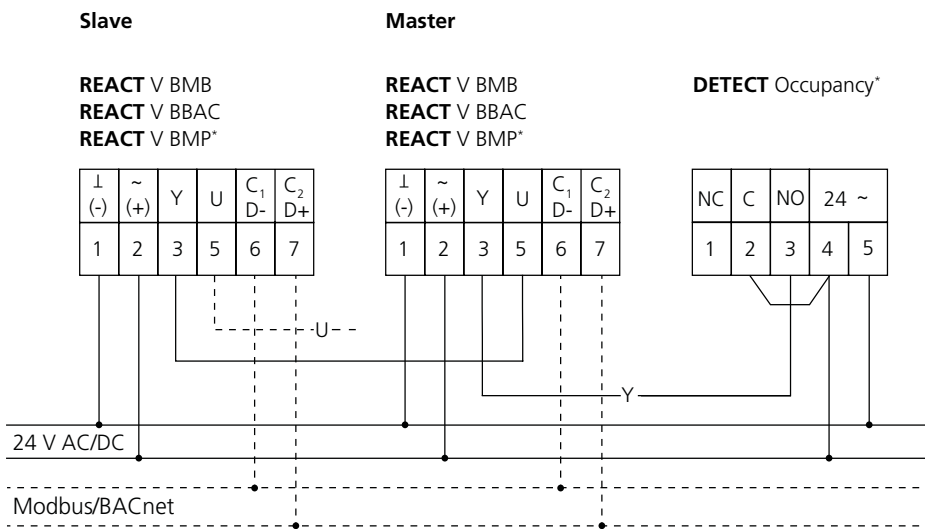

\*Modbus/BACnet communication not available

## Notes

---



---



---



---

# Balanced air flow control with temperature and CO<sub>2</sub> function

Air flow measurement and regulating damper that variably controls the air flow between minimum and maximum flow rate depending on the current temperature and the CO<sub>2</sub> content in the room. The air flow value from the master damper is sent analogously to the slave damper to maintain the balance in the room.

Demand control via analogue control signal (Y). Return of the current air flow via analogue actual value signal (U). Possibility of Modbus/BACnet communication in combination with analogue control signals.

## Settings

### Air flow regulation – Slave

- Vmin : 0
- Vmax : Vnom on Master
- Mode : Same as Master
- Set point source : Analogue
- Bus protocol : Modbus alt BACnet

### Air flow regulation – Master

- Vmin : Minimum air flow
- Vmax : Maximum air flow
- Mode : 0 - 10 V
- Set point source : Analogue
- Bus protocol : Modbus alt BACnet

## Wiring diagram

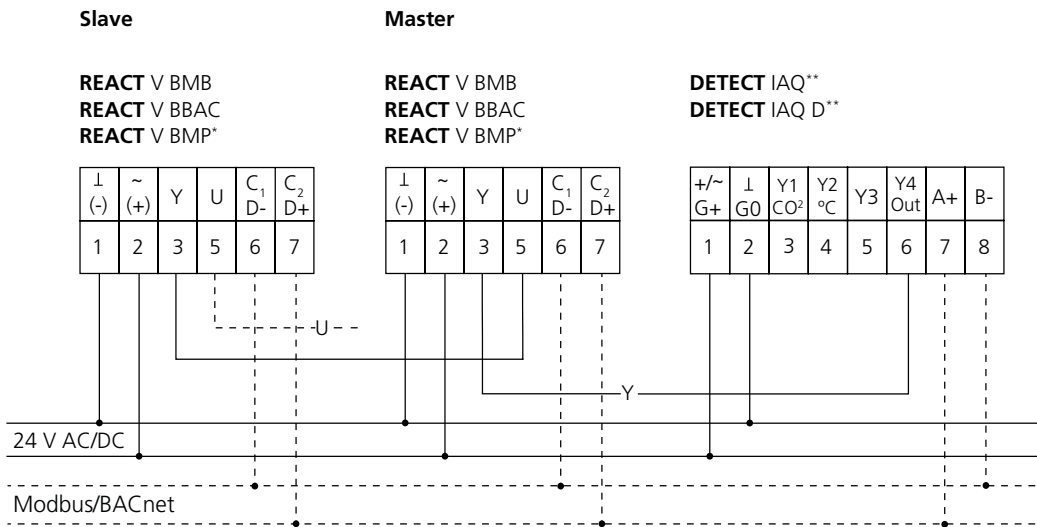

\*Modbus/BACnet communication not available  
 \*\*BACnet communication not available

## Notes

---



---



---



---



# Balanced air flow control with temperature, CO<sub>2</sub> and occupancy function

Air flow measurement and regulating damper that variably controls the air flow between the minimum and maximum flow rate depending on the current temperature and the CO<sub>2</sub> content in occupancy mode. Occupancy is detected via internal occupancy sensor. The damper is regulated to minimum flow rate in no-occupancy mode. The air flow value from the master damper is sent analogously to the slave damper to maintain the balance in the room.

Demand control via analogue control signal (Y). Return of the current air flow via analogue actual value signal (U). Possibility of Modbus/BACnet communication in combination with analogue control signals.

## Settings

### Air flow regulation – Slave

- Vmin : 0
- Vmax : Vnom on Master
- Mode : Same as Master
- Set point source : Analogue
- Bus protocol : Modbus alt BACnet

### Air flow regulation – Master

- Vmin : Minimum air flow
- Vmax : Maximum air flow
- Mode : 0 (2)-10 V
- Set point source : Analogue
- Bus protocol : Modbus alt BACnet

## Wiring diagram

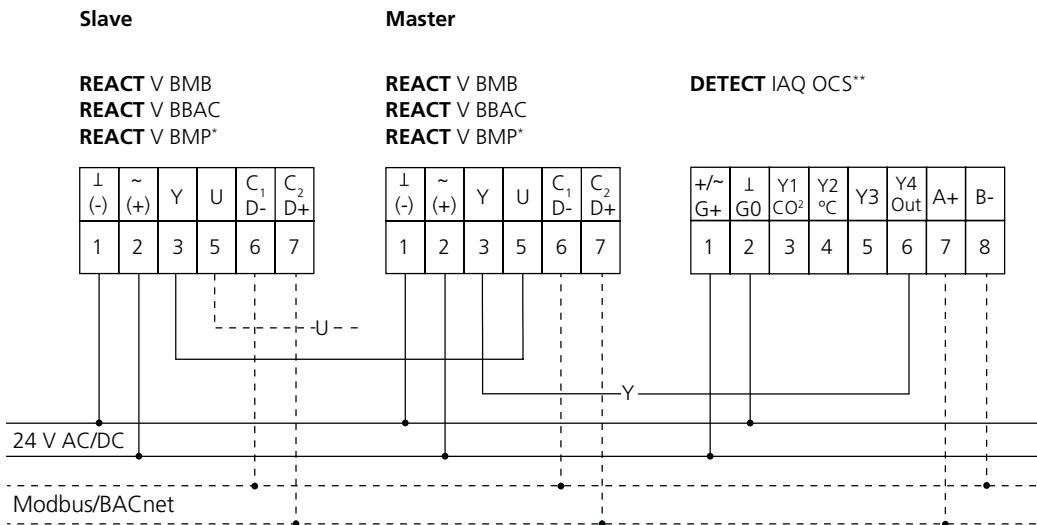

\*Modbus/BACnet communication not available  
 \*\*BACnet communication not available

## Notes

---



---



---



# Balanced air flow control with temperature controller for demand control and temperature regulation

Air flow measurement and regulating damper that variably controls the air flow between the set minimum and maximum flow rate (cooling function) depending on the temperature set point. The air flow value from the master damper is sent analogously to the slave damper to maintain the balance in the room. The wiring diagram also shows the alternative with RTCT duct temperature sensor and thermo-actuator (Ts) for heating function.

Demand control via analogue control signal (Y). Return of the current air flow via analogue actual value signal (U). Possibility of Modbus/BACnet communication in combination with analogue control signals.

## Settings

### Air flow regulation – Slave

Vmin : 0  
 Vmax : Vnom on Master  
 Mode : Same as Master  
 Set point source : Analogue  
 Bus protocol : Modbus alt BACnet

### Air flow regulation – Master

Vmin : Minimum air flow  
 Vmax : Maximum air flow  
 Mode : 0 - 10 V  
 Set point source : Analogue  
 Bus protocol : Modbus alt BACnet

## Wiring diagram

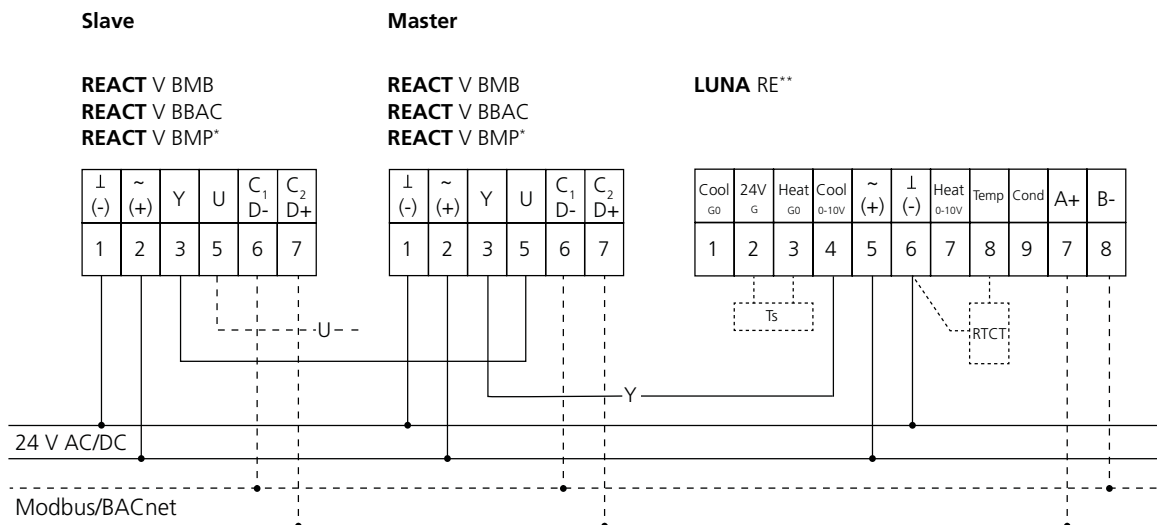

\*Modbus/BACnet communication not available  
 \*\*BACnet communication not available

## Notes

---



---



---

# Balanced air flow control with controller for demand control

Air flow measurement and regulating damper that variably controls between the minimum and maximum flow rate depending on the control signal. The air flow value from the master damper is sent analogously to the slave damper to maintain the balance in the room.

Demand control via analogue control signal (Y). Return of the current air flow via analogue actual value signal (U). Possibility of Modbus/BACnet communication in combination with analogue control signals.

## Settings

### Air flow regulation – Slave

- Vmin : 0
- Vmax : Vnom on Master
- Mode : Same as Master
- Set point source : Analogue
- Bus protocol : Modbus alt BACnet

### Air flow regulation – Master

- Vmin : Minimum air flow
- Vmax : Maximum air flow
- Mode : 0 (2)-10 V
- Set point source : Analogue
- Bus protocol : Modbus alt BACnet

## Wiring diagram

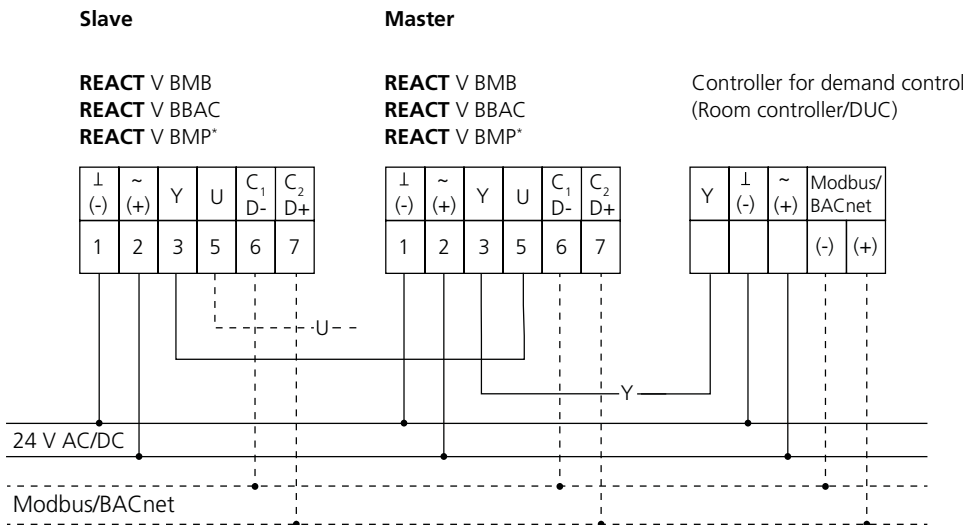

\*Modbus/BACnet communication not available

## Notes

---



---



---



---

# Balanced air flow control with temperature controller and temperature adjustment for demand control via external occupancy sensor

Air flow measurement and regulating damper that variably controls between the set minimum and maximum flow rate (cooling function) depending on the set temperature set point in occupancy mode. Occupancy is detected via external occupancy sensor. The room is regulated to minimum flow rate in no-occupancy mode. The air flow value from the master damper is sent analogously to the slave damper to maintain the balance in the room. The wiring diagram also shows the alternative with RTCT duct temperature sensor and thermo-actuator (Ts) for heating function.

Demand control via analogue control signal (Y). Return of the current air flow via analogue actual value signal (U). Possibility of Modbus/BACnet communication in combination with analogue control signals.

## Settings

### Air flow regulation – Slave

- Vmin : 0
- Vmax : Vnom on Master
- Mode : Same as Master
- Set point source : Analogue
- Bus protocol : Modbus alt BACnet

### Air flow regulation – Master

- Vmin : Minimum air flow
- Vmax : Maximum air flow
- Mode : 0 - 10 V
- Set point source : Analogue
- Bus protocol : Modbus alt BACnet

## Wiring diagram

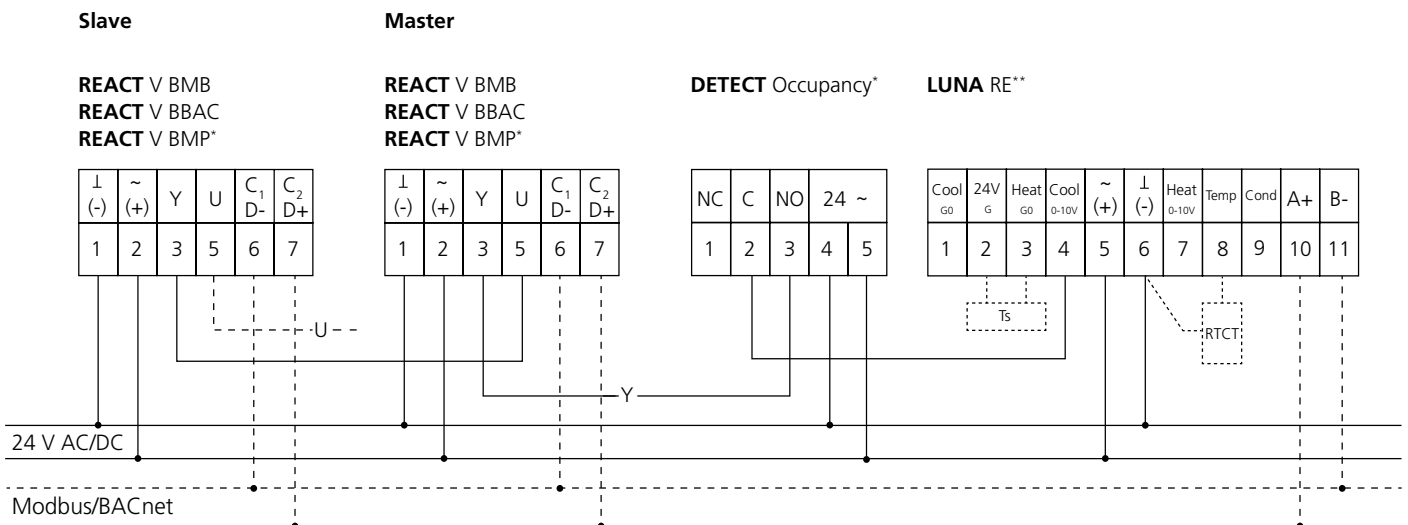

\*Modbus/BACnet communication not available  
 \*\*BACnet communication not available

## Notes

---



---



---



---

# Balanced air flow control with controller for demand control via external occupancy sensor

Air flow measurement and regulating damper that variably controls between the minimum and maximum flow rate depending on the control signal in occupancy mode. Occupancy is detected via external occupancy sensor. The room is regulated to minimum flow rate in no-occupancy mode. The air flow value from the master damper is sent analogously to the slave damper to maintain the balance in the room.

Demand control via analogue control signal (Y). Return of the current air flow via analogue actual value signal (U). Possibility of Modbus/BACnet communication in combination with analogue control signals.

## Settings

### Air flow regulation – Slave

- Vmin : 0
- Vmax : Vnom on Master
- Mode : Same as Master
- Set point source : Analogue
- Bus protocol : Modbus alt BACnet

### Air flow regulation – Master

- Vmin : Minimum air flow
- Vmax : Maximum air flow
- Mode : 0 (2)-10 V
- Set point source : Analogue
- Bus protocol : Modbus alt BACnet

## Wiring diagram

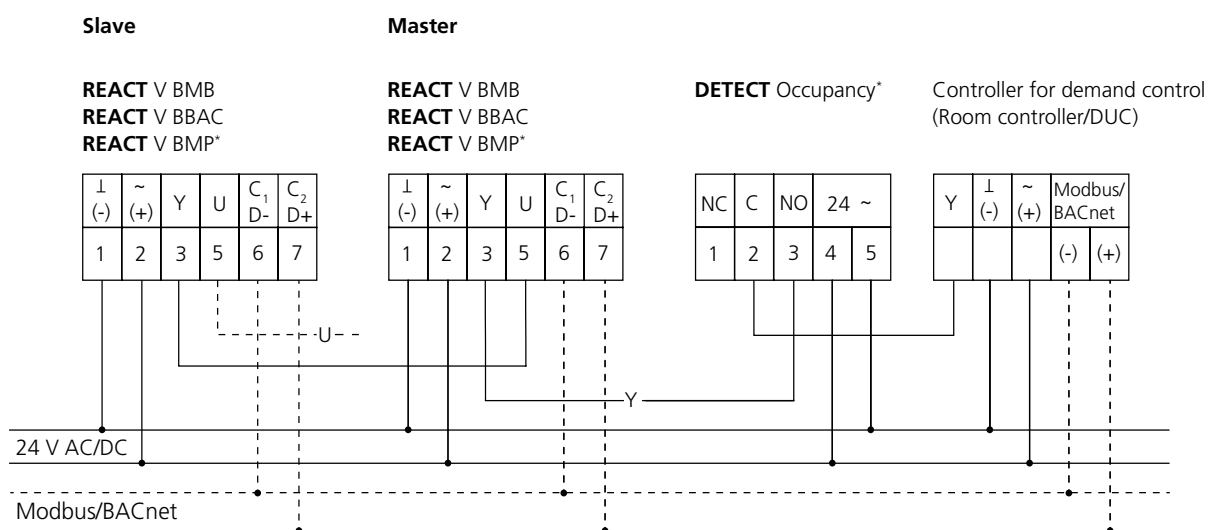

\*Modbus/BACnet communication not available

## Notes

---



---



---



---

# Balanced air flow control with temperature controller for demand control and absence control

Air flow measurement and regulating damper that variably controls the air flow between the set minimum and maximum flow rate (cooling function) depending on the temperature set point in occupancy mode. The room is set to absence set point in no-occupancy mode. The air flow value from the master damper is sent analogously to the slave damper to maintain the balance in the room. The wiring diagram also shows the alternative with RTCT duct temperature sensor and thermo-actuator (Ts) for heating function.

Demand control via analogue control signal (Y). Return of the current air flow via analogue actual value signal (U). Possibility of Modbus/BACnet communication in combination with analogue control signals.

## Settings

### Air flow regulation – Slave

- Vmin : 0
- Vmax : Vnom on Master
- Mode : Same as Master
- Set point source : Analogue
- Bus protocol : Modbus alt BACnet

### Air flow regulation – Master

- Vmin : Minimum air flow
- Vmax : Maximum air flow
- Mode : 0 - 10 V
- Set point source : Analogue
- Bus protocol : Modbus alt BACnet

## Wiring diagram

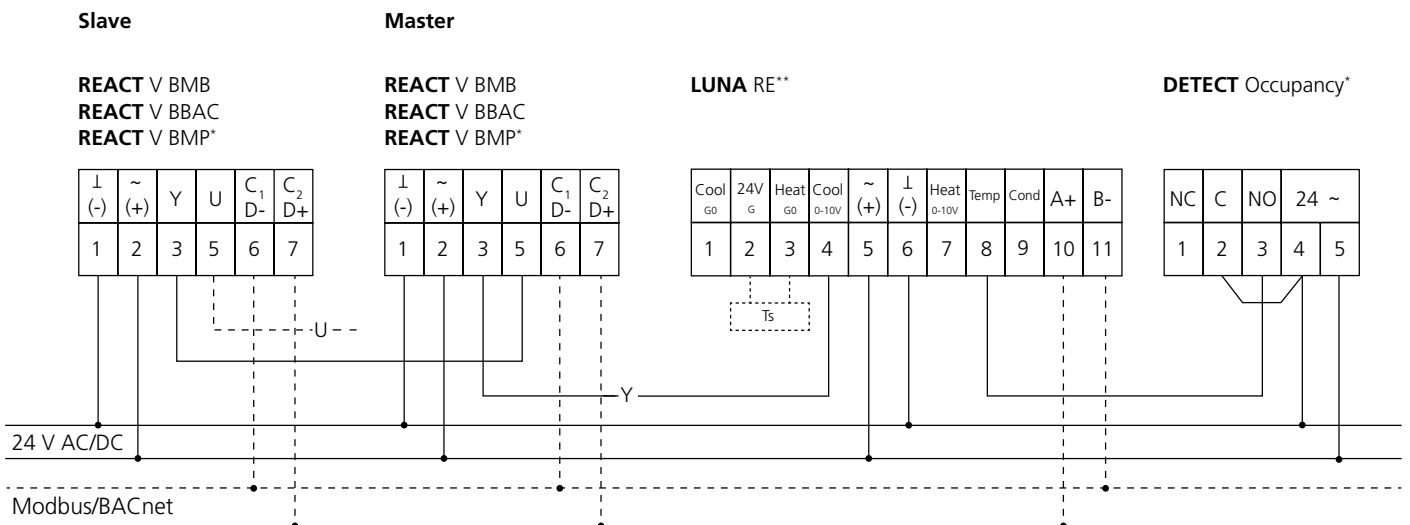

\*Modbus/BACnet communication not available  
 \*\*BACnet communication not available

## Notes

---



---



---