

VHC

Controller for diffuser readjustment



QUICK FACTS

- Adapted for diffusers BOC, CKD and FALCON
- Can also control a motorised damper with on/off function
- Adjustable change-over temperature 1-5 °C
- Supplied complete with room and duct sensors
- Can control up to 10 diffusers
- Temperature sensor of PT1000 type

Technical description

General

VHC is used to readjust diffusion for both cooling and heating supply air units. Temperature difference between supply air and room temperature is used as regulating parameter.

Design

VHC is an electronic controller that compares the room temperature with the supply air temperature and switches the diffuser between horizontal and vertical air pattern with increasing over temperature. The switching operation is performed according to the two position principle. A LED mounted on the circuit board, which illuminates in heating mode. The change-over point with increasing temperature is adjustable between 1-5°C. VHC is supplied complete with duct and room temperature sensors. The controller is installed with a duct sensor on a shelf, which can be adapted to most duct sizes, circular as well as rectangular.

Materials and surface treatment

The electronics are enclosed in a ABS/PC-plastic case. The assembly shelf is made of galvanized sheet steel. The duct temperature sensor is made of stainless steel.

Installation

VHC with duct temperature sensor is installed in the supply air duct at maximum of 1 m before the first diffuser to be controlled. The room sensor is installed on a wall, suitably between 1.5 to 2 m above the floor. The temperature sensor must not be exposed to direct sunlight or air flow directly from the supply air diffuser. It is important that the room temperature sensor is installed in a representative position. See Figure 1 and 2.

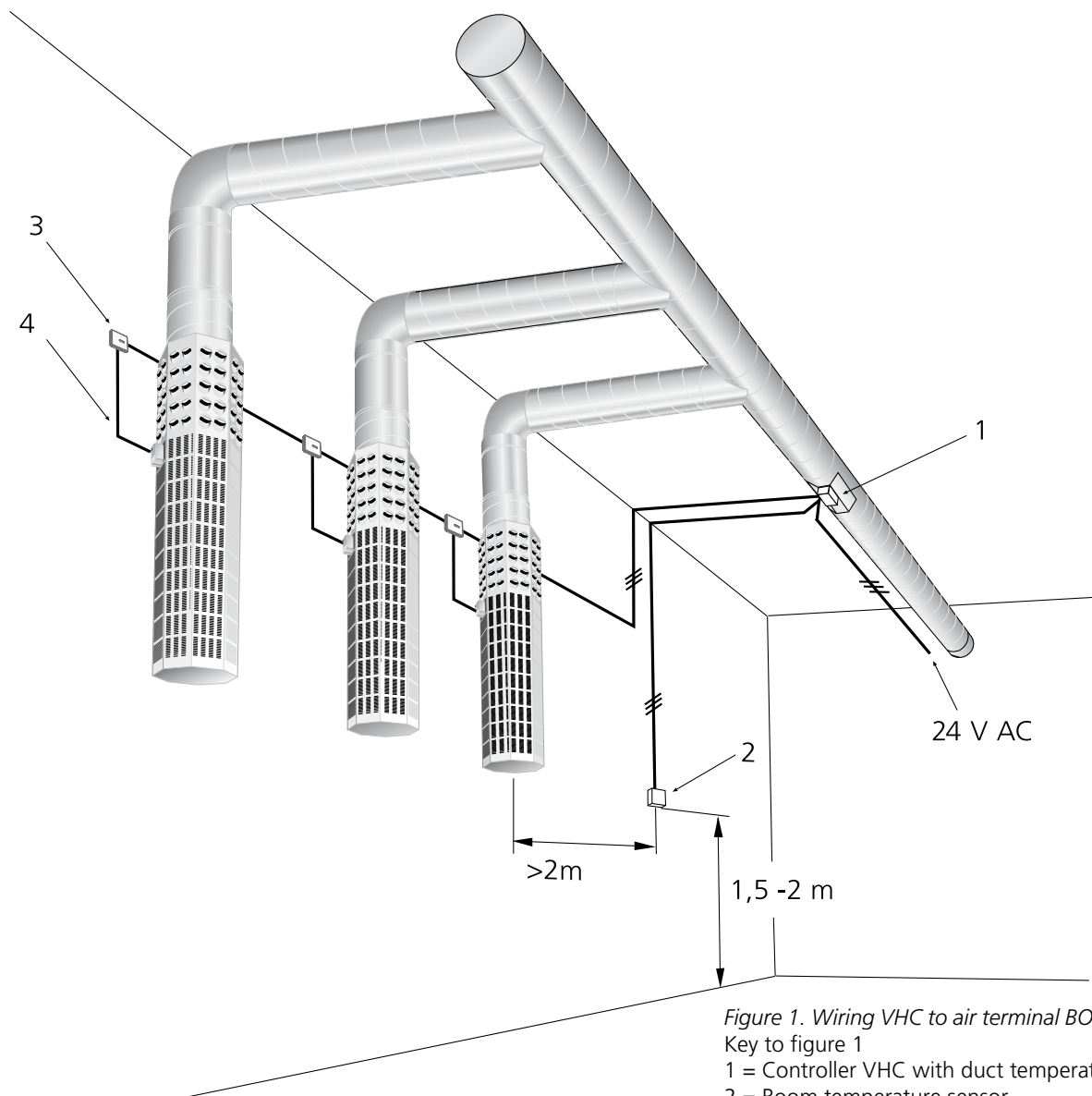

Figure 1. Wiring VHC to air terminal BOC.

Key to figure 1

- 1 = Controller VHC with duct temperature sensor
- 2 = Room temperature sensor
- 3 = Junction box, not included in the delivery
- 4 = Fixed motor cable 0.4 m

Connection

VHC is connected to a 24 V AC power supply. Connection is made in accordance with the wiring diagram, see separate document; "Installation – Commissioning – Maintenance".

Maintenance

Dirty products are cleaned by dusting or wiping with a damp cloth.

Environment

The environmental product declaration is available from www.swegon.com.

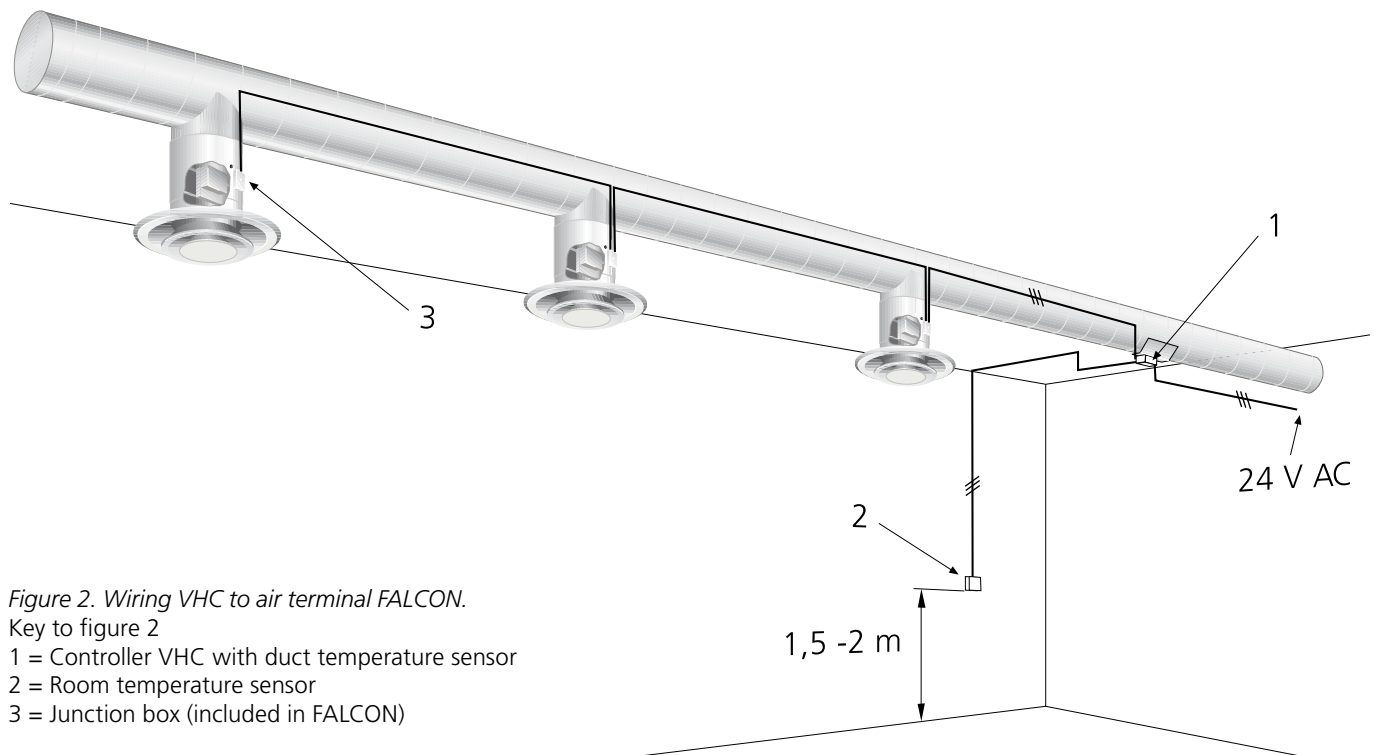

Sizing

Ambient temperature:

Operation 0 °C – +50 °C

Storage –40 °C – +70 °C

Storage Relative humidity max. 90% RH, non condensing

Enclosure:

Material ABS/PC-plastic grey

Protection class VHC IP 54

Room sensor IP 30

Sensor PT1000

Accuracy, sensor, 0 to + 35°C ±0,3 °C

Time constant approx. 7 min

Voltage supply 24 V AC ±10%

Power consumption 1,5 VA

Power consumption of the diffuser's damper motor should be added to the overall power consumption.

Dimensions

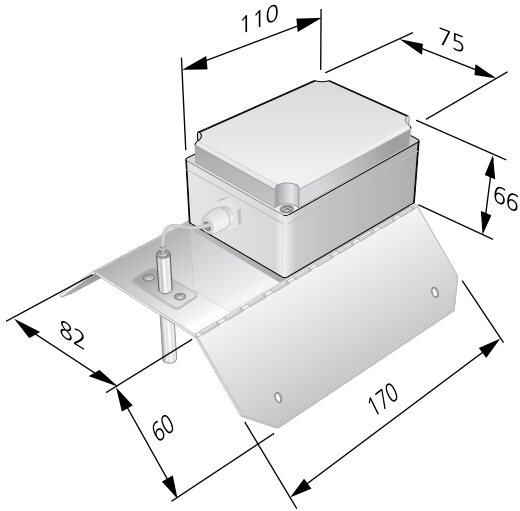

Figure 3. VHC controller with duct temperature sensor.

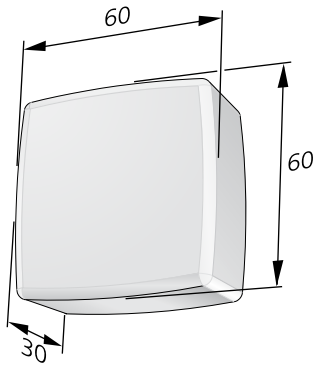

Figure 4. Room temperature sensor.

Order key

Product

Controller

VHCa

Specification example

Swegons controller for diffusers with change-over between heating / cooling with following functions:

- Temperature sensor of PT1000 type
- Adjustable change-over temperature

Type:

VHCa

xx items